

## Universal Twin Pumps

Universal Twin pumps are designed for installation into vented systems to pump both the hot and cold water supplies - boosting both equally. Suitable for both positive and negative head applications.

Universal pumps do not require a gravity flow of water to start.



### Features

- Robust brass construction
- 1.5 - 4.5 bar performance options
- Continuously rated
- EPDM/PTFE/Al. Oxide seal
- G 3/4 threaded connections
- Pre-wired with 1.5 metre power cable
- Anti-vibration feet
- 5 year guarantee (subject to conditions)
- **UK Specification:** Supplied with 22 mm push-in x 300 mm anti-vibration flexible hoses with integral isolating valves
- **ROI Specification:** Supplied with 21 mm push-in x 300 mm anti-vibration flexible hoses with integral isolating valves
- **Export Specification:** Supplied with G 3/4 female x 300 mm long hoses

### Application

- Boost hot and cold water services to the complete home, bathroom, kitchen or cloakroom.
- Pressurise the supply in applications such as loft conversions, where outlets are higher than the water source.

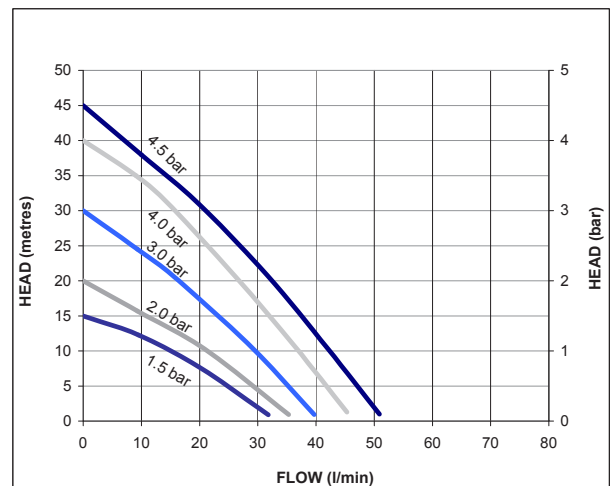

# monsoon

Pump Model		U2.0 bar Twin 472454	U3.0 bar Twin 619313	U4.0 bar Twin 619314
General	Guarantee	5 years		
	WRAS approval	1404701		
Features	Pump type	Peripheral		
	Mechanical seal	EPDM/PTFE/Al.Oxide		
	Anti-vibration feet	✓	✓	✓
	Inlet strainer(s)	✓	✓	✓
	Flexible hoses	4	4	4
	Run on Timer	3 sec	3 sec	3 sec
	Dry run protection	✓	✓	✓
Materials	Pump body	Brass		
	Impeller	Brass		
Performance	Maximum head (closed valve)	2.0 bar	3.0 bar	4.0 bar
	Performance @ 9 l/min	1.5 bar	2.5 bar	3.5 bar
	Performance @ 18 l/min	1.1 bar	1.9 bar	2.8 bar
	Maximum flow	35 l/min	40 l/min	45 l/min
	Maximum static inlet pressure	12 metres		
	Maximum static outlet pressure	12 metres		
	Maximum working pressure*	600 kPa (6bar)		
	Maximum ambient air temperature	40 °C		
	Min / Max water temperature**	Min 4 °C / Max 65 °C		
	Flow switch sensitivity (approx)	0.6 l/min		
	Pressure vessel air pre-charge	0.9 bar 913psi)		1.3 bar (18.5 psi)
Connections	Pump connections	G ¾ male		
Flexible hoses	Connections (UK model)	G ¾ female x 22 mm push-in x 300 mm long, isolating valves on all hoses		
	Connections (ROI model)	G ¾ female x 21 mm push-in x 300 mm long, isolating valves on all hoses		
	Connections (Export model)	G ¾ female x G ¾ female x 300 mm long		
Motor	Type	Induction, auto-reset thermal trip		
	Duty rating	Continuous (S1) @ 9 l/min and above		
Electrical	Power supply / phase / frequency	230 V a.c / 1 / 50 Hz		
	Current (full load)	1.9 Amps	2.9 Amps	3.9 Amps
	Power consumption	435 Watts	655 Watts	875 Watts
	Fuse rating	13 Amps		
	Power cable (pre-wired)	1.5 metres		
Physical	Enclosure protection	IPX4		
	Length	265 mm		300 mm
	Width	162 mm		
	Height (excluding hoses)	243 mm		
	Weight (including fittings)	8.8 Kg	9.2 Kg	11.1 Kg

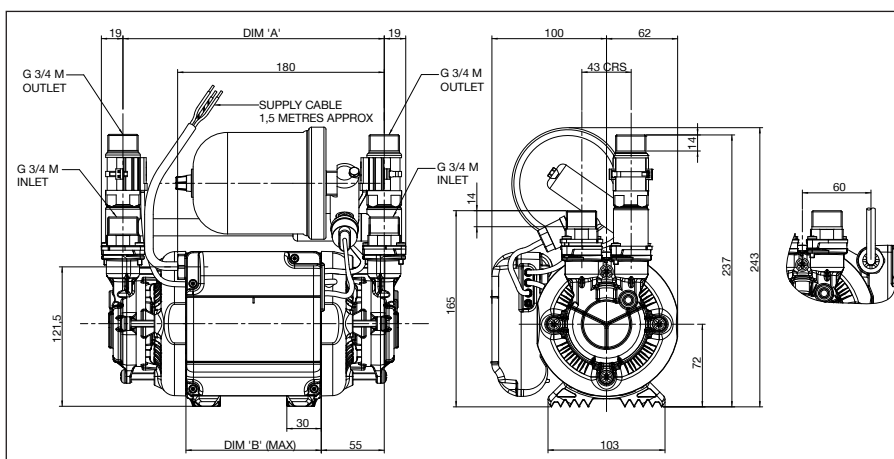

\* The maximum pressure that can be applied to the pump under any installation conditions.

\*\* A stored water temperature of 60 °C is considered sufficient to meet all normal requirements and will minimise deposition of scale in hard water areas.

\*\*\* Both heads pumping 4.5 l/min and above.

Pump Description	Dim. 'A'	Dim. 'B'
U2.0 bar Twin	227 mm	119 mm
U3.0 bar Twin	227 mm	119 mm
U4.0 bar Twin	262 mm	154 mm

Stuart Turner Limited reserves the right to amend specifications without notice.