

ECA & EVA

Extractors

Installation, use and maintenance

Contents

- 3 Important information
- 4 Important notes
- 6 Using your extractor (ECA range)
- 7 Using your extractor (EVA range)
- 8 Care and maintenance
- 9 Changing the charcoal filter
- 10 LED lights
- 11 Mains electricity connection
- 12 Electrical information
- 13 Mounting your extractor
- 14 Installation and ducting
- 15 Installation diagrams
- 16 Installation diagrams
- 19 Energy efficiency information

Important

The CDA Group Ltd cannot be held responsible for injuries or losses caused by incorrect use or installation of this product. Please note that CDA reserve the right to invalidate the guarantee supplied with this product following incorrect installation or misuse of the appliance or use in a commercial environment.

This appliance is not designed to be used by people (including children) with reduced physical, sensorial or mental capacity, or who lack experience or knowledge about it, unless they have had supervision or instructions on how to use the appliance by someone who is responsible for their safety.

Under no circumstances should any external covers be removed for servicing or maintenance except by suitably qualified personnel.

Appliance information:

Please enter the details on the appliance rating plate below for reference, to assist CDA Customer Care in the event of a fault with your appliance and to register your appliance for guarantee purposes.

Appliance Model	
Serial Number	

Declarations of Conformity:

This appliance has been manufactured to comply with all EU & UK statutory requirements and complies with all applicable legislation and the following European Directives:

- The Low Voltage Directive 2014/35/EU
- Electromagnetic Compatibility Directive 2014/30/EU

The product has been marked with the UKCA and CE symbols.



This appliance is marked according to the European directive 2004/104/EC on Waste Electrical and Electronic equipment (WEEE).

IMPORTANT INFORMATION FOR CORRECT DISPOSAL OF THE PRODUCT IN ACCORDANCE WITH EC DIRECTIVE 2002/96/EC.

At the end of its working life, the product must be taken to a special local authority waste collection centre or to a dealer providing appliance recycling services.

Disposing of a household appliance separately avoids possible negative consequences for the environment and health. It also enables the constituent materials to be recovered, saving both energy and resources. As a reminder of the need to dispose of household appliances separately, the product is marked with a crossed-out wheeled dustbin .

Please note:

- Under no circumstances should the extractor be connected to any gas ventilation system, flue system or hot air ducting system.
- Do not vent the extractor into an attic or loft space.
- Only install the extractor in rooms with adequate ventilation. Remember that the extractor is powerful and whatever air is extracted needs to be replaced.
- Do not tile the extractor in. It should be removable for service or maintenance.
- Do not use silicone sealant to secure the extractor to the wall.
- You must be able to isolate the extractor from the mains electrical supply after installation.
- This extractor has been designed to be used in a room with a volume of less than 36m³.

-
- Steam cleaners must not be used when cleaning this appliance.
 - The performance of your extractor will vary depending on a number of factors. These include: type of extraction, length of ducting, room volume, ventilation available and cleanliness of the filters.

Note:

For best performance, you should switch on the extractor 15 minutes before starting to cook and leave it to run for approximately 15 minutes after the end of cooking.

Using Your Extractor (ECA Range)

Control Panel

A - Light button

B - Speed level buttons

C - Power off button

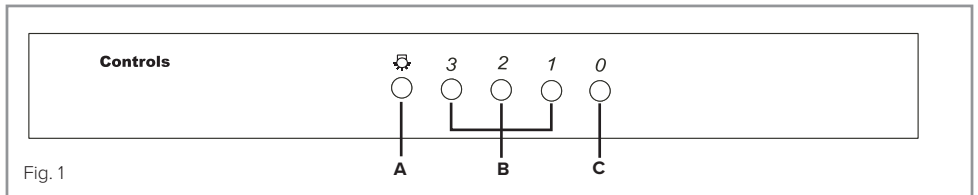

To switch the extractor light on or off:

- Press button “A”.

To switch on the extractor or to change the speed at any time when the extractor is running:

- Press the relevant “B” button for the first, second or third speed level as required.

To switch the extractor off:

- Press button “C”.

Using Your Extractor (EVA Range)

Control Panel

A - Speed level keys

B - Light key

C - Off key

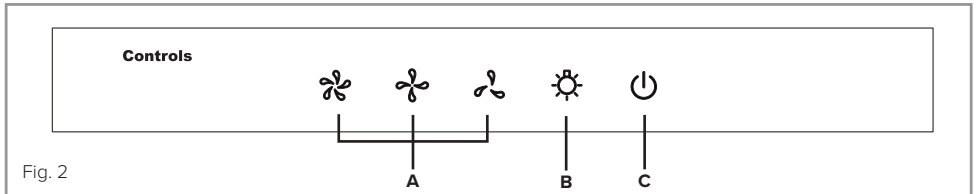

Fig. 2

To switch on the extractor or to change the speed at any time when the extractor is running:

- Touch the relevant key "A" for the first, second or third speed level as required.

To switch the extractor light on or off:

- Touch key "B".

To switch the extractor off:

- Touch key "C" **twice**.

To activate the "Timer" mode:

- Touch key "C" **once** when the extractor is already running. This will set the extractor to run for a further 15 minutes before automatically stopping.

Care and Maintenance

IMPORTANT : DO NOT PERFORM MAINTENANCE OR CLEANING OF THE EXTRACTOR WITHOUT FIRST SWITCHING OFF THE ELECTRICITY SUPPLY.

Cleaning

You should use a nonabrasive cleaner. Any abrasive cleaner (including Cif) will scratch the surface and could erase the control panel markings.

You can clean your extractor effectively by simply using a dilute solution of water and mild detergent and drying to a shine with a clean cloth, such as a microfibre cloth.

Cleaning the grease filter

The grease filter should be kept clean to minimise the risk of fire.

At least once a month you should remove the grease filter and clean it with hot soapy water. You can also wash the grease filter in a dishwasher, ensuring that you place it in an upright position to prevent damage from other items in the dishwasher.

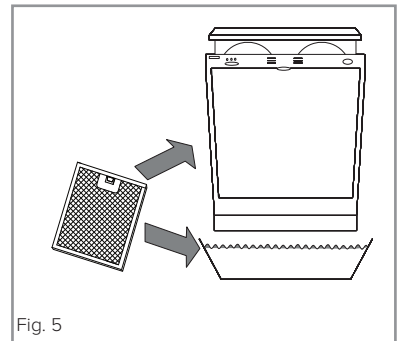
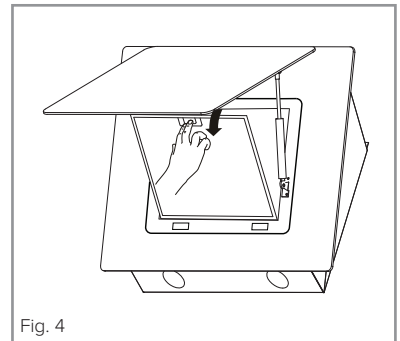
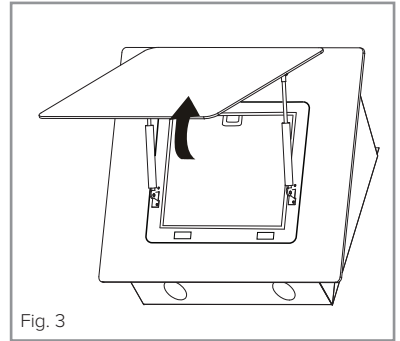

To remove the grease filter

- Open the hinged panel as shown in Fig. 3.
- Push in the button on the handle and then pull down on the filter at the top as shown in Fig. 4.
- When you have released it at the top, then you can pull the filter out completely.

After rinsing and drying, reassemble the grease filter to the hood by reversing the removal process.

Please note:

Cleaning the grease filter in the dishwasher may lead to discolouration. This is normal and does not constitute a fault with the appliance.

Changing the charcoal filter (re-circulating only)

To ensure best performance of your extractor, you should replace the charcoal filter every four to six months, depending on use.

To attach the charcoal filters:

- Remove the grease filter as described above.
- Slide the charcoal filters into their locations on the motor casing as in this photo. Two filters are required, one to go at each end of the motor.
- Finally, replace the grease filter.

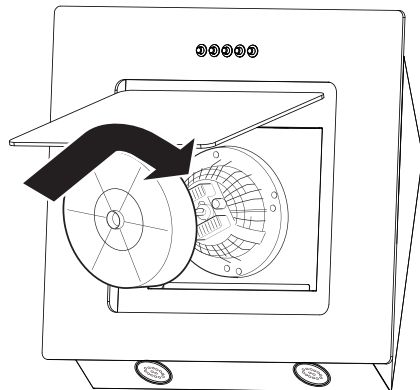

IMPORTANT: Steam cleaners must not be used to clean this appliance.

The LED lights

In case of malfunction of the illumination system contact the technical service.

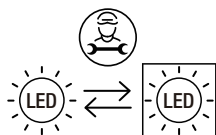

Replaceable (LED only) light source by a professional

Mains Electricity Connection

THIS APPLIANCE MUST BE CONNECTED TO THE MAINS SUPPLY BY A COMPETENT PERSON, USING FIXED WIRING VIA A DOUBLE POLE SWITCHED FUSED SPUR OUTLET AND PROTECTED BY A 3A FUSE.

We recommend that the appliance is connected by a qualified electrician, who is a member of the N.I.C.E.I.C. and who will comply with the I.E.T. and local regulations.

The wires in the mains lead of this appliance are coloured in accordance with the following code:

Green & Yellow = Earth

Blue = Neutral

Brown = Live

As the colours of the wires in the mains lead for the appliance may not correspond with the coloured markings identifying the terminals connecting to the fused spur, proceed as follows:

- The wire which is coloured green and yellow must be connected to the terminal marked “E” (Earth) or coloured green.
- The wire which is coloured blue must be connected to the terminal marked “N” (Neutral) or coloured black.
- The wire which is coloured brown must be connected to the terminal marked “L” (Live), or coloured red.

Note: Use a 3A Fuse.

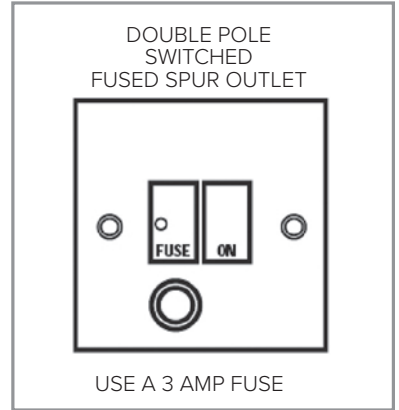

Assembly and electrical connection should be carried out by specialised personnel.

When installing this product we recommend you seek the help of another individual.

Electrical Information

Mains electrical voltage: 230 – 240Vac

Total rated power consumption:

114W

If your extractor is not working:

1. Check that the mains supply has not been switched off.
2. Check that the fuse in the spur has not blown.

Mounting Your Extractor

Your extractor can be used to filter and recycle the air within your kitchen, or to extract the air outside.

When installing this appliance over a CDA hob, the clearance between the extractor and the hob must be equal to or exceed 550mm. This instruction overrides the instructions supplied with the CDA hob. (The height should be measured from the top of the hotplates or burners).

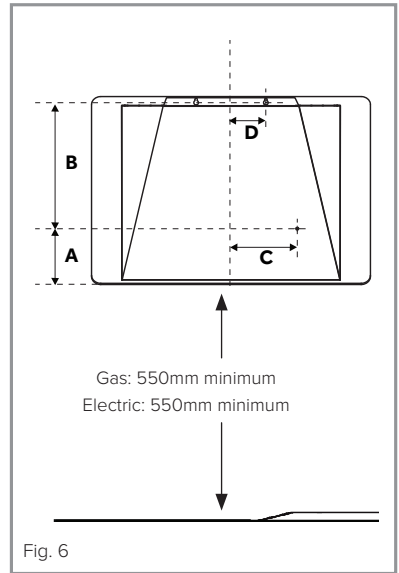

Where the extractor is to be installed above a non-CDA hob, the instructions supplied with the hob may dictate that the height required above the hob is greater than 550mm.

	ECA	EVA
A	138	138
B	282	282
C	85	85
D	75	75

IN THE ABSENCE OF ANY INSTRUCTIONS SUPPLIED WITH A GAS HOB, THE MINIMUM DISTANCE BETWEEN THE HOB AND EXTRACTOR MUST BE AT LEAST 760mm.

The width of any hob must not be greater than the width of the extractor installed above it.

Installation

The metal casing of this appliance has been coated with a preservative to protect it during transport and storage. This should be removed during installation by using a non-abrasive stainless steel cleaner. Always follow the instructions given with the cleaner being used.

When correctly installed, your product meets all safety requirements laid down for this type of product. However, special care should be taken around the rear of the appliance as these areas are not designed or intended to be touched and may contain sharp or rough edges that could cause injury.

Ducting and Ventilation

For best performance and lowest noise output, we recommend the use of 125mm ducting. 100mm ducting may be used but this will reduce performance and increase the noise of the extractor.

The ducting used should be rigid circular pipe and must be manufactured from fire retardant material, produced to BS 476 or DIN 4102-B1. The lengths of ducting with minimal effect on performance are as follows:

- 4 metres with 1 x 90° bend.
- 3 metres with 2 x 90° bends.
- 2 metres with 3 x 90° bends.

Longer ducting can be used but the performance of the extractor will likely be reduced.

Tools required.

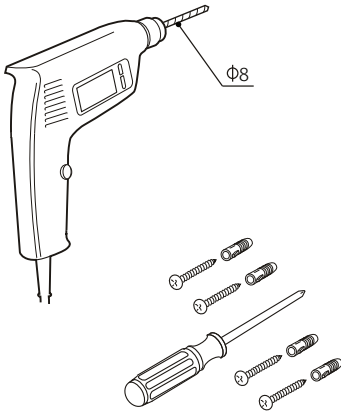

Fig. 7

Mark out wall as required, see Fig 6.

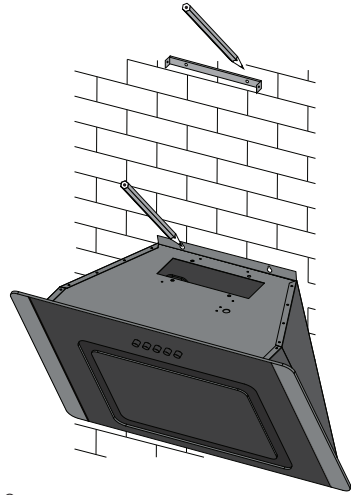

Fig. 8

Drill five mounting holes.

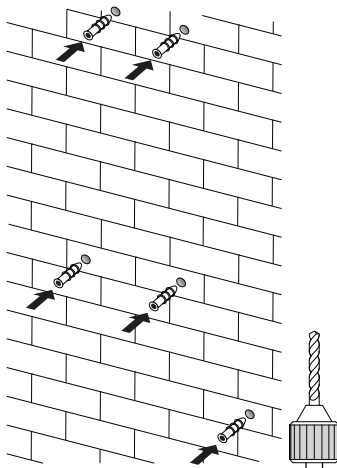

Fig. 9

Fit wall fixings and top screws. Ensure that any fixings you use are appropriate for the wall type.

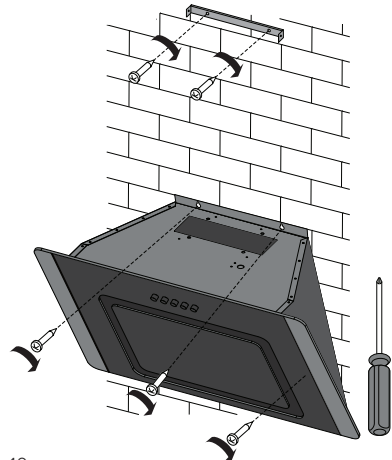

Fig. 10

IMPORTANT SAFETY WARNING: ONLY USE THE SCREWS PROVIDED WITH THE EXTRACTOR TO MOUNT THE DUCTING ADAPTOR. THE USE OF LONGER SCREWS MAY CAUSE DAMAGE TO THE INTERNAL WIRING WHICH WILL NOT BE COVERED BY THE WARRANTY.

Fit the ducting adaptor.

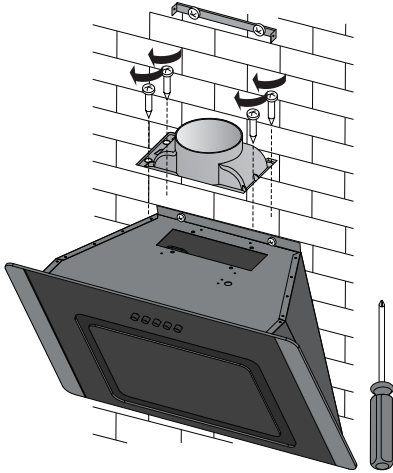

Fig. 11

Fix ducting and seal joints.

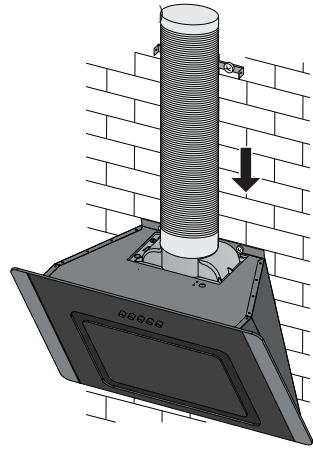

Fig. 12

Mount the chimney.

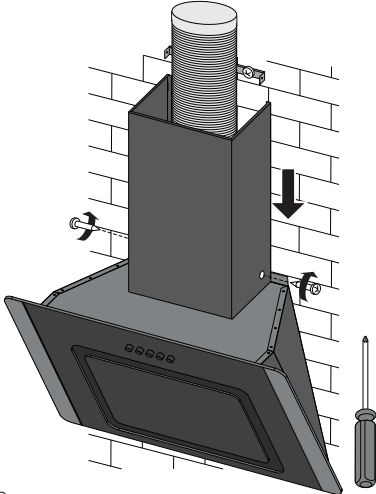

Fig. 13

Adjust and secure the chimney.

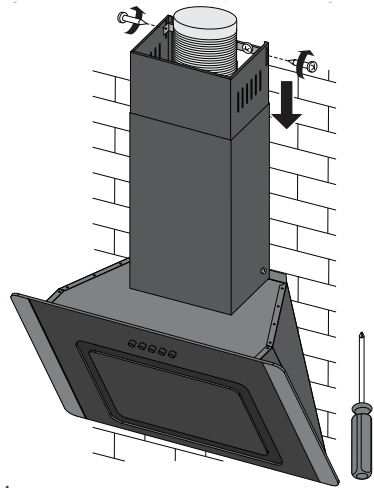

Fig. 14

NOTES

NOTES

Energy Efficiency Information

Attribute	Symbol	Value		Units
Model identification		ECA60	EVA60, EVA70 & EVA90	
Annual Energy Consumption	AEC_{Hood}	45.2	45.2	kWh
Time increase factor	f	1.3	1.3	
Fluid Dynamic Efficiency	FDE_{Hood}	19.0	19.0	
Energy Efficiency Index	EEI_{Hood}	68.0 (B)	68.0 (B)	
Measured airflow at Best Efficiency Point	Q_{BEP}	186.5	186.5	m ³ /h
Measured Pressure at Best Efficiency Point	P_{BEP}	326	326	Pa
Maximum airflow	Q_{MAX}	350	350	m ³ /h
Measured electric power at Best Efficiency Point	W_{BEP}	89.0	89.0	W
Nominal lighting power	WL	4	4	W
Average illumination of the lighting system on the cooking surface	E_{Middle}	450	300	Lux
Measured power consumption in standby	P_s	--	0.7	W
Measured power consumption off mode	P_o	0	0.47	W
Sound power level	L_{WA}	64	64	dBA
Grease Filter Efficiency	GFE_{Hood}	37 (G)	37 (G)	%
Lamp Efficiency	LE_{Hood}	112 (A)	75 (A)	%

E & O E. All instructions, dimensions and illustrations are provided for guidance only. CDA reserve the right to change specifications without prior notice.

For service or queries relating to your product please contact:

The Customer Care Department on **01949 862 012** or email **customer.care@cda.co.uk**

For more information please contact:

The Sales Department on **01949 862 010** or email **sales@cda.co.uk**

Customer Care Department. The CDA Group Ltd, Harby Road, Langar, Nottinghamshire, NG13 9HY
T: 01949 862 012 **F:** 01949 862 003 **E:** customer.care@cda.co.uk