

FW582

Integrated freezer

Installation, use and maintenance

Contents:

- 3 Important information
- 4 Important safety information
- 6 Before first use
- 7 Use
- 8 Storage and use
- 9 Controls and use
- 10 Care and cleaning
- 10 Defrosting the freezer
- 11 Practical tips
- 12 Troubleshooting
- 17 Mounting the fascia doors
- 19 Reversing the freezer door
- 20 Climate Range
- 21 Electrical Informaion

Important

The CDA Group Ltd cannot be held responsible for injuries or losses caused by incorrect use or installation of this product. Please note that CDA reserve the right to invalidate the guarantee supplied with this product following incorrect installation or misuse of the appliance or use in a commercial environment.

This appliance is not designed to be used by people (including children) with reduced physical, sensorial or mental capacity, or who lack experience or knowledge about it, unless they have had supervision or instructions on how to use the appliance by someone who is responsible for their safety.

Under no circumstances should any external covers be removed for servicing or maintenance except by suitably qualified personnel.

Appliance information:

Please enter the details on the appliance rating plate below for reference, to assist CDA Customer Care in the event of a fault with your appliance and to register your appliance for guarantee purposes.

Appliance Model	
Serial Number	

EU Declarations of Conformity

This appliance has been designed, constructed and marketed in compliance with safety requirements of EU Directive 2014/35/EU (Low voltage) and requirements of EU Directive 2014/30/EU (EMC).

This appliance has been manufactured to the strictest standards and complies with all applicable legislation, including Electrical safety (LVD) and Electromagnetic interference compatibility (EMC). Parts intended to come into contact with food conform to 1935/2004/EC.

This refrigeration appliance is intended for use as a built-in appliance

IMPORTANT INFORMATION FOR CORRECT DISPOSAL OF THE PRODUCT IN ACCORDANCE WITH EC DIRECTIVE 2012/19/EU.

At the end of its working life, the product must not be disposed of as urban waste. The refrigeration system contains insulating gases and refrigerants, which require specialised waste disposal. The valuable materials contained in this appliance can be recycle. It must be taken to a special local authority differentiated waste collection centre or to a dealer providing this service.

Before disposing of an old appliance, remove the door seals, latch or bolt lock to avoid the risk of child entrapment.

Disposing of a household appliance separately avoids possible negative consequences for the environment and health deriving from inappropriate disposal and enables the constituent materials to be recovered to obtain significant savings in energy and resources. As a reminder of the need to dispose of household appliances separately, the product is marked with a crossed-out wheeled dustbin. 

Important safety information

- Never store inflammable or explosive items and strong corrosive acids or alkalis in the appliance.
- This is a household appliance, which is produced in accordance with the national standard. It is intended for food storage only, not for storage of blood, medicine and biological products.
- To prevent risk of fire, keep the appliance away from petrol or any other inflammables.
- To prevent risk of electromagnetic interference or other accidents, do not place a microwave oven on top of the freezer or use any electric appliance inside the freezer.
- Do not allow children to play with or near the appliance.
- The internal surface of the freezer compartment is very cold when the appliance is running. Do not touch the surface especially when hands are wet.
- Do not splash water onto the appliance. Keep it away from places of high humidity that may have adverse effect on the electric insulation performance.
- This appliance is designed to be used in ambient temperatures between 10 and 32°C. Use outside of this range may cause the appliance to fail.

Before first use

You must allow the freezer to settle for at least twenty four hours prior to switching the power on.

It is recommended that you clean the interior of the appliance prior to first use, using a solution of bicarbonate of soda and warm water and then thoroughly drying the interior.

The freezer may have an odour to it at first use. This will disappear as the appliance cools.

When first switching the appliance on it is advisable to set the freezer to setting 3 on the thermostat dial and leaving the freezer to settle for 24 hours before adjusting the temperature to the preferred setting.

Please note:

The appliance will work continuously until it comes down to the correct temperature.

If the appliance is switched off, you should allow five minutes before switching it on again to prevent unnecessary damage to the compressor.

Never store inflammable or explosive items and strong corrosive acids or alkalis in the appliance.

The presence of frosting within the compartments is not a malfunction of the freezer.

Use

Freezer

- The freezer compartments are designed to store only frozen food.
- Never put hot or warm foods in the freezer, allow them to cool fully before putting them into the freezer.
- Follow the instructions on the food packaging for storage of frozen food. If no information is provided, foods should not be stored for more than three months after the purchase date.
- Store food in small packages (ideally less than 2.5kg). This reduces the freezing time and improves the quality of the food after thawing.
- Wrap food before putting into the freezer. To stop the wrapping sticking together, ensure it is dry.
- Label the food before freezing with information including type of food and dates of storage and expiry.
- Once food is thawed, it must not be refrozen unless it has been completely cooked. Only defrost as much food as is required, to prevent wastage.
- Bottled or canned drinks should not be stored in the freezer compartments as they could explode.
- Check the rating plate to confirm the maximum amount of fresh food that can be frozen within a 24 hour period.
- Do not attempt to freeze more than the maximum amount.
- To freeze fresh food more quickly, switch the dial to setting 5 a few hours prior to placing the food in the freezer.

Note: If the appliance does not have a freezer compartment () it is not suitable for freezing foodstuffs.

Storage and use

This freezer is suitable for storing deep frozen food (food which has already been frozen before being added to the freezer), for storing fresh food for a short period (2-3 weeks) by freezing it and for making ice and ice cream.

Always remember to observe and adhere to the recommended expiration date of food.

Fresh food, and food which needs to be stored for a long period, should be kept at a temperature of -18°C or below. For this, we recommend using setting 4 or 5.

If food only needs to be stored for a short period then a setting of 2 or 3 will suffice.

Please remember: Ice cream or ice for drinks should be allowed to sit at room temperature for several minutes before being used as they can still be cold enough to cause damage to skin and lips.

Please note: The freezer should be defrosted regularly. If you are unsure of when then it is advisable to do so when and if the ice layer reaches 5mm thickness.

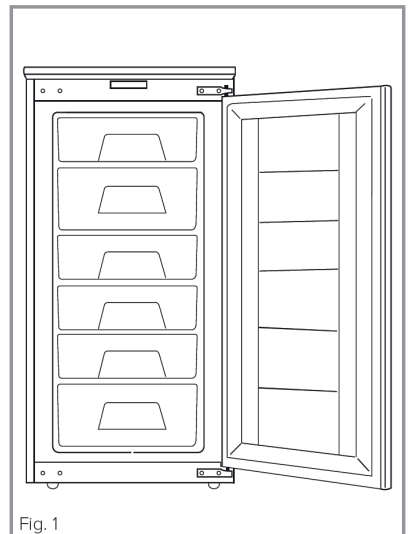
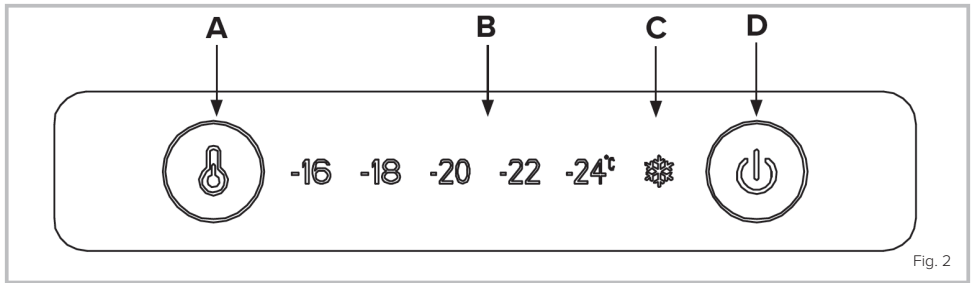

Fig. 1

Controls and use



A. Freezer temperature adjustment sensor

This button is used to adjust the temperature within the freezer. Press this sensor once to activate adjustment, and then as many times as necessary until the desired level is selected. The settings range from -16 to -24 with -16 being the warmest and -24 being the coldest.

B. Freezer temperature setting display

This display will illuminate the current temperature setting. Adjusting the temperature will cycle through this display.

C. Super freeze function

This should be used when freezing large quantities of food all at once. Activate this function 2 or 3 hours before introducing the food and do not leave it to run for more than necessary. Leaving it to run for longer will place unnecessary strain on the cooling system. The function will automatically deactivate after approximately 24 hours.

Please note: You do not use the numbers to change the temperature. Instead, use the refrigerator temperature adjustment sensor (A).

D. Power button

Use this sensor to switch the appliance on and off (standby mode). The sensor will be illuminated when the appliance is off.

Care and cleaning

Always disconnect the appliance from the power supply before any cleaning or maintenance.

The freezer should be cleaned using a solution of bicarbonate of soda and lukewarm water. Do not use abrasive products or detergents. After washing, rinse and dry thoroughly.

Clean the drawers separately by hand with a mild solution of washing up liquid and water. Do not put them in the dishwasher.

If the appliance is not to be used for prolonged periods of time, unplug and clean the appliance. The doors should be left slightly ajar to prevent the formation of mildew and unpleasant odours. It is important however that you ensure that no child or person could become trapped in the appliance.

Defrosting the freezer

Do not use heaters or defrosting sprays in this appliance.

Never use any metallic or sharp objects such as knives or forks to remove the ice as this could damage the lining.

The freezer compartment should be defrosted regularly to ensure the most efficient running of the freezer.

Once the ice is more than 5mm thick, the freezer should be defrosted.

- 24 hours before defrosting the freezer, turn the thermostat dial to setting 5 to ensure the frozen food is fully frozen.
- Before switching off the freezer, wrap the the frozen food in sheets of paper and store it in a cool place.
- Switch the appliance off at the thermostat dial and the mains and then remove the freezer drawers.
- To speed up the defrosting process, place a bowl of warm water in the base of the freezer compartment.
- The freezer should be cleaned using a solution of bicarbonate of soda and lukewarm water. Do not use abrasive products or detergents. After washing, rinse and dry thoroughly.
- Clean the drawers separately by hand with a mild solution of washing up liquid and water. Do not put them in the dishwasher.
- Once cleaning is complete, reconnect the power.

Practical tips

To achieve the most effective food preservation for the longest possible time and to avoid wasting any food, position the products as shown in Fig. 1. In addition this figure illustrates the layout of drawers, and shelves, which allows the most efficient use of energy.

Optimal temperature and storage conditions will extend product shelf life and optimise electricity consumption. Optimal storage temperature range should be stated on the food packaging.

Troubleshooting

If you have any problems with your appliance, you should check the troubleshooting prior to calling CDA Customer Care to prevent unnecessary service calls and potential cost.

If the appliance is not working, check the following:

- There is power to the appliance and the green power light is on.
- The house fuses are intact and the fuse in the plug has not blown.
- The on/off switch is not set to off.
- The plug socket is functioning fine. To check this, plug another electrical appliance in to see if the socket is faulty.

If the appliance is working, but not very well, check the following:

- The appliance is not overloaded.
- The thermostat is set to an appropriate temperature.
- The doors are closing properly.
- The cooling system at the rear of the appliance is clean and free of dust, and not touching the rear wall.
- There is enough ventilation at the side and rear walls.

If the appliance is noisy, check the following:

- The appliance is level and stable.
- The side and rear walls are clear, and there is nothing resting on the appliance.
- Note: The cooling gas in the refrigerator may make a slight bubbling or gurgling noise, even when the compressor is not running.

If there is water in the freezer, check the following:

- The appliance has power and the green power light is on.
- There are no items touching the rear wall of the appliance. If there are, adjust their position so that they no longer touch it.
- That there is some resistance when opening the door of the appliance. If it opens at the slightest touch it may mean that the door seal needs to be replaced.
- Inspect the door seal for any kinks, debris or damage. If you notice any, and are unable to resolve the issue yourself, contact CDA Customer Care so that the seal can be replaced.

If excessive ice or frost has formed in the freezer:

- It is normal for some ice and frost to form in the freezer. This does not constitute a fault with the appliance. If the ice layer is thicker than 5mm, try defrosting the appliance.
- Ensure that the thermostat is at the position you intend for it to be and hasn't been accidentally set to the highest setting. If the freezer is set to the maximum, try lowering the setting.
- Check that there is some resistance when opening the door of the appliance. If it opens at the slightest touch it may mean that the door seal needs to be replaced.
- Check the door seal for any kinks, debris or damage. If you notice any, and are unable to resolve the issue yourself, contact CDA Customer Care so that the seal can be replaced.

If the temperature warning light () is on:

- It may mean that your door seal is defective. Carry out the above two door seal checks. If the door has been reversed recently, check page 20. If the problem persists, contact CDA Customer Care.

Installation and Ventilation

This appliance must never be installed close to heat sources, e.g. heating elements, cookers or in damp places.

- To ensure the appliance is level, you should use the height adjustable feet at the front of the appliance.
- The cooling system at the rear of the appliance must not touch the rear wall or cabinet.
- The appliance must be installed with adequate ventilation. Ensure that there is clearance above the appliance to allow air to escape and that there is space between the rear of the appliance and the wall.

Fig. 5 shows the ventilation requirements for your appliance. Failure to provide adequate ventilation can lead to increased running costs, premature failure and may invalidate the warranty provided with the appliance. Further information regarding ventilation is supplied on page.

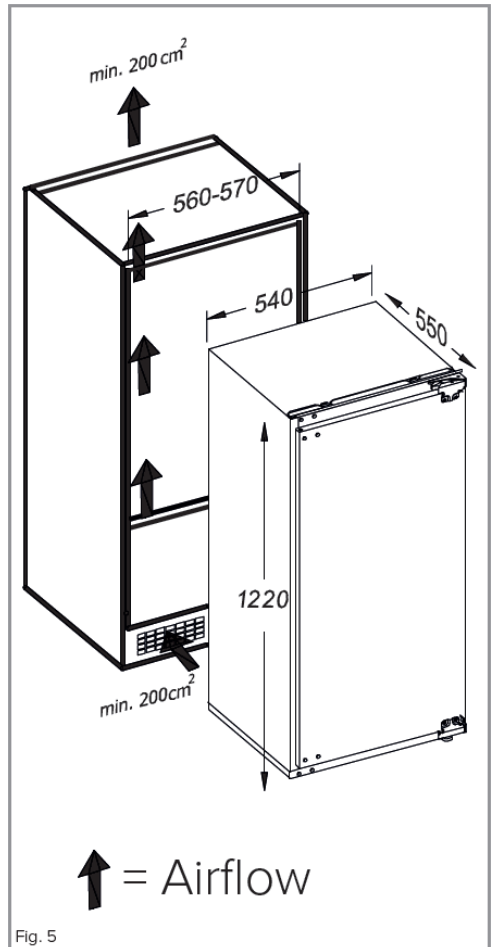

Ventilation

The main consideration when installing any refrigeration unit into a fitted kitchen is ventilation. The heat removed from the cooling compartment needs to be dissipated into the atmosphere. Incorrect ventilation can lead to premature compressor failure, excessive power consumption and total system failure. For products intended to be installed into a housing unit, the following requirements need to be met:

Important

Please follow the instructions to install this unit.

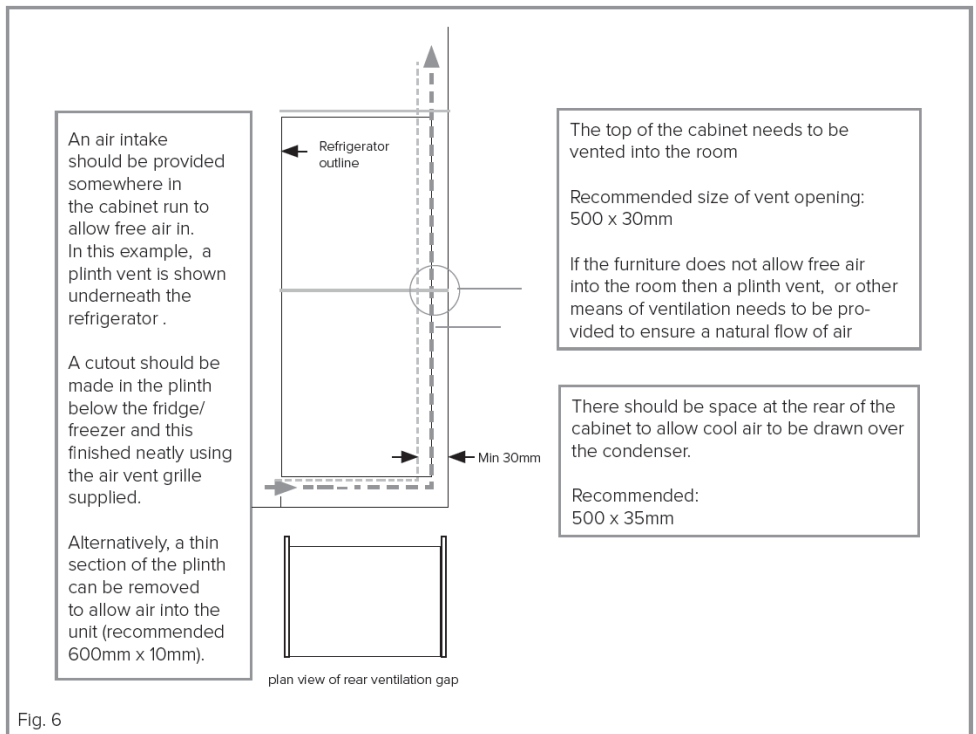

Fig. 6

The open channel at the rear is clearly shown. For the correct operation of the appliance it is important that the top of the housing unit is not blocked off. A channel depth of 40-50mm is normal with most units.

A ventilation hole is required in the plinth of the unit; this allows air to be drawn over the compressor & heat exchange. A decorative grille is supplied with the appliance to finish this vent neatly. Alternatively the required air flow can be achieved by removal of a thin section of plinth (recommended 600mm x 10mm minimum).

As a rule, the more air that can get in to the furniture cabinet, the better and more efficient the operation of the product.

Mounting the fascia doors

Fig. 8 - Fitting the decor door bracket

Remove the white decorative cover (Fig. 7) by lifting it upwards.

Obtain the below measurements:

Dimension B= Measure from the underside surface of kitchen unit to the bottom of fixing bracket.

Dimension C= Measure from the underside surface of kitchen unit to the top of next unit door.

Unscrew and remove the nuts and washers from the top of the appliance door to remove the bracket.

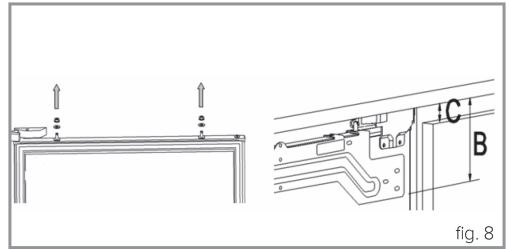
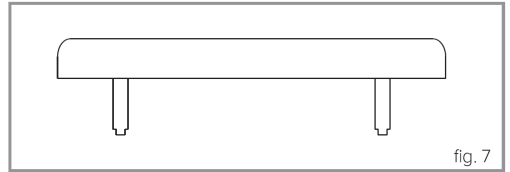

Fig. 9 - Fitting the decor door bracket

Subtract C from B and put the fixing bracket (2) in place using this measurement for vertical position and place to the centre for horizontal position. Secure the fixing bracket (2) using screws (1).

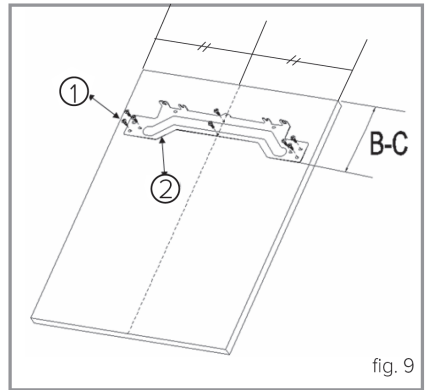

Fig. 10 - Fitting the decor door

Place the decor door onto the appliance door by inserting adjustment bolts into the slots on the fixing bracket. Locate the washers and screw the nuts onto the adjustment bolts.

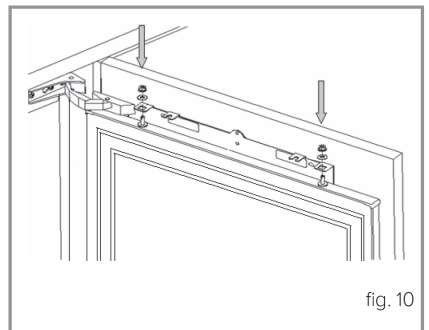
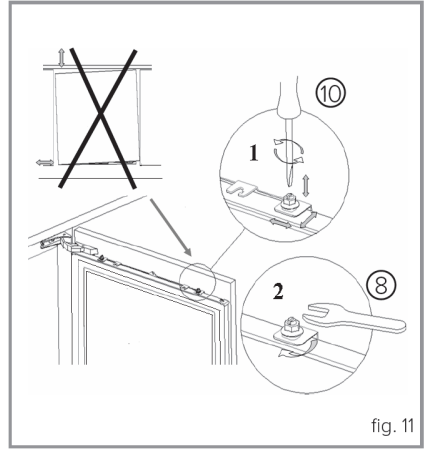

Fig. 11 - Aligning the decor door

Close the door and check the alignment with the other unit doors. Adjust the decor door by screwing or unscrewing the adjustment bolts for vertical adjustment and by the help of the slots on the fixing bracket for other directions. Lock the screws into place as shown in Fig. 11.



Fitting the decor door base fixings

With the appliance door open, locate the metal decor door base fixing brackets and screw the fixings to the decor door. You may need to remove and re-fit these brackets depending upon the decor door used.

Fitting the decorative cover

Re-fit the decorative cover, that you removed in the first step, on to the decor door fixing bracket.

Check that the whole door assembly operates smoothly and that the door seal of the freezer is still creating a seal.

Reversing the freezer door

We recommend you seek the help of another individual to support the doors whilst performing this operation.

1. Open the door.
2. Carefully prise off the white cover caps for the side that you wish to switch the hinges to.
3. Loosen the screws that hold the hinges to the freezer cabinet and remove the door.
4. Remove the screws that secure the hinge to the door.
5. Place the door somewhere safe where it will not cause or receive damage.
6. Relocate the hinges to their opposing corners as shown in Fig. 12.
7. Refit the door to the hinges.

Do not turn the door upside down.

8. Insert the cover caps (3) on the opposite side in the exposed holes.
9. Ensure that the door seal is correct, as per page 19.

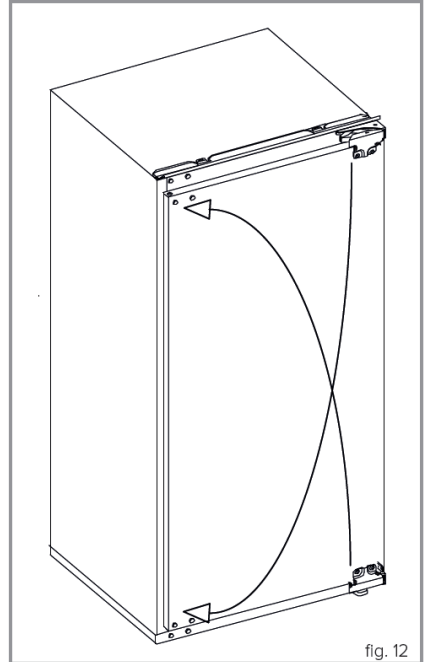

Ensuring the door seals correctly:

It is normal for the seal to be compressed after the door has been reversed.

With the door closed, use a hair dryer to expand the seal and fill the gap between the door and the body of the appliance.

Take care not to use the hair dryer too close to the appliance, which could damage the seal. A distance of approximately 10cm should be adequate.

When completed, allow the seal and door to cool before touching them.

Once done, the seal will remain in position.

Climate Range

The information about the climate range of the appliance is provided on the rating plate. It indicates at which ambient temperature (that is room temperature in which the appliance is working) is optimal for the operation of the appliance.

Climate class		Allowable ambient temperature
SN	Extended Temperate	This refrigeration appliance is intended for use at an ambient temperature ranging between 10°C and 32°C
N	Temperate	This refrigeration appliance is intended for use at an ambient temperature ranging between 16°C and 32°C
ST	Sub Tropical	This refrigeration appliance is intended for use at an ambient temperature ranging between 16°C and 38°C
T	Tropical	This refrigeration appliance is intended for use at an ambient temperature ranging between 16°C and 43°C

Electrical Information

Warning! This appliance must be earthed.

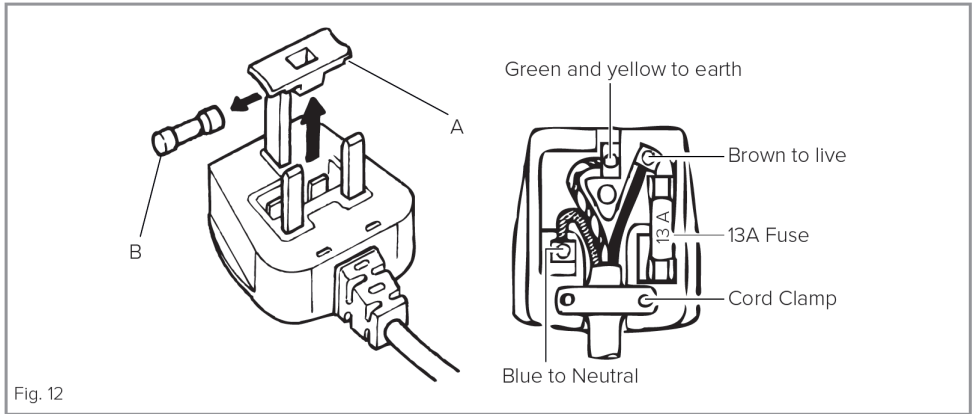

The mains lead of this appliance has been fitted with a BS 1363A 13Amp fused plug. To change a fuse in this type of plug, follow the steps below:

1. Remove the fuse cover and fuse.
2. Fit replacement 13A fuse, ASTA approved to BS 1362 type, into the fuse cover.
3. Replace fuse cover.

Important: Do not use the appliance without the fuse cover in position.

How to connect an alternative plug

If the fitted plug is not suitable for your socket outlet, then it should be cut off and disposed of safely to avoid possible shock hazard. A suitable alternative plug of at least 13 Amp rating to BS 1363 should be used.

As the colours of the wires in the mains lead of this appliance may not correspond with the coloured markings identifying the terminals in your plug, proceed as follows:

- The wire which is coloured GREEN and YELLOW must be connected to the terminal which is marked with letter (E) or by the Earth symbol or coloured GREEN and YELLOW.
- The wire which is coloured BLUE must be connected to the terminal which is marked with the letter (N) or coloured BLACK.
- The wire which is coloured BROWN must be connected to the terminal which is marked with the letter (L) or coloured RED.

If in doubt regarding the electrical connection of this appliance, consult a qualified electrician. Do not shorten the supply cable, the appliance may require removing for servicing.

N.B. Ensure that the plug socket is situated in an easily accessible place after installation.

E & O E. All instructions, dimensions and illustrations are provided for guidance only. CDA reserve the right to change specifications without prior notice.

For service or queries relating to your product please contact:

The Customer Care Department on **01949 862 012** or email **customer.care@cda.co.uk**

For more information please contact:

The Sales Department on **01949 862 010** or email **sales@cda.co.uk**

Customer Care Department. The CDA Group Ltd, Harby Road, Langar, Nottinghamshire, NG13 9HY
T: 01949 862 012 F: 01949 862 003 E: customer.care@cda.co.uk