

# PoziDry

# Compact Pro

## Positive Input Ventilation Unit

Installation and Wiring Instructions

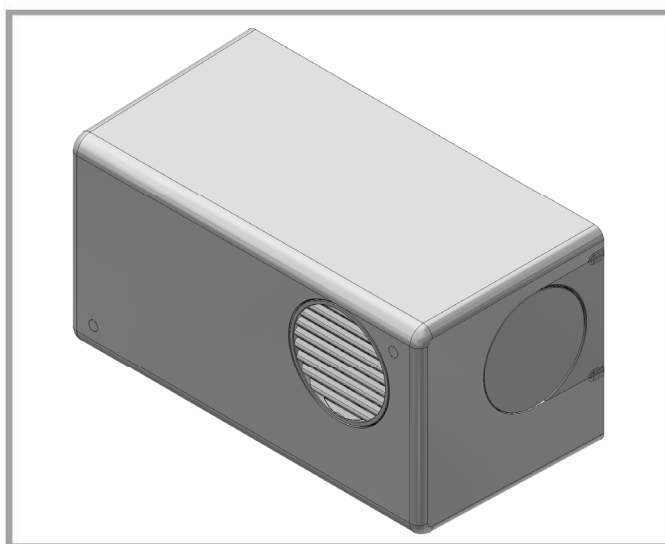

**Stock Ref. N°**

479188 – PoziDry Compact Pro

**220-240V~50Hz**

***Vent-Axia***<sup>®</sup>

PLEASE READ INSTRUCTIONS IN CONJUNCTION WITH THE ILLUSTRATIONS.

PLEASE SAVE THESE INSTRUCTIONS

**UK  
CA  
CE**

# Installation and Wiring Instructions for the PoziDry Compact Pro Positive Ventilation Unit.

## **INTRODUCTORY NOTES**

The Unit is a positive input ventilation unit, designed to be installed on a wall of a dwelling to continually supply filtered fresh air into the building. The system consists of a fan unit with heater.

The Unit has an adjustable speed settings. These speeds are set during installation; there are 2 pre-set speeds or an option allowing the speeds to be chosen manually from 10 L/s - 30 L/s. The Unit uses a sensor to monitor the supply temperature into the room. If the ambient room temperature exceeds 27°C (adjustable during commissioning), the unit will automatically switch to standby (no airflow), unless installed in radon mode (selectable during commissioning).

All models are supplied with a heater; the element is activated by default when the supply air temperature drops below the adjustable threshold. The heater will try and maintain the supply air temperature at the threshold temperature. The threshold temperature can be adjusted during commissioning.

The unit also incorporates a data logging function. This function will display total runtime of system, energy consumption of the fan and energy consumption of the heater. This data is resettable (when in data logging menu, hold the + and – button for 15 seconds until you see the word “RESET” on the display).

## **SAFETY AND GUIDANCE NOTES**



**IMPORTANT: READ THESE INSTRUCTIONS BEFORE  
COMMENCING THE INSTALLATION**

1. DO NOT install this product in areas where the following may be present or occur:
  - 1.1. Excessive oil or a grease laden atmosphere.
  - 1.2. Corrosive or flammable gases, liquids or vapours.
  - 1.3. Ambient temperatures higher than 40°C or less than -10°C.
  - 1.4. Possible obstructions which would hinder access or removal of the Fan.
  - 1.5. Relative humidity above 90%
  - 1.6. Sudden ductwork bends or transformations close to the Unit.
  - 1.7. To achieve optimal airflow, the unit should be mounted 1.8m from floor level.
2. All wiring to be in accordance with the current I.E.E. Regulations, or the appropriate standards of your country and MUST be installed by a suitably qualified person.
3. The fan must be provided with a 3A fused, isolator switch capable of disconnecting all poles, having a contact separation of at least 3mm.
4. Ensure that the mains supply (voltage, frequency, and phase) complies with the fan's rating label.
5. The fan should not be used where it is liable to be subjected to direct water spray.
6. This appliance can be used by children aged from 8 years and above and persons with reduced physical, sensory or mental capabilities or lack of experience and knowledge if they have been given supervision or instruction concerning use of the appliance in a safe way and understand the hazards involved. Children shall not play with the appliance. Cleaning and user maintenance shall not be made by children without supervision.
7. Precautions must be taken to avoid the back-flow of gases into the room from the open flue of gas or other fuel-burning appliances.
8. Children of less than 3 years should be kept away unless continuously supervised.
9. Children aged from 3 to 8 years shall only switch on/off the appliance provided the unit is installed as intended for normal operation and they have been given

supervision or instruction concerning safe use of the appliance and understand the hazards involved.

10. Children aged 3 to 8 shall not plug in, regulate and clean the appliance or perform user maintenance.

**Caution - some parts of this product can become very hot and cause burns. Particular attention has to be given where children and vulnerable people are present.**

### **UNIT SIZE**

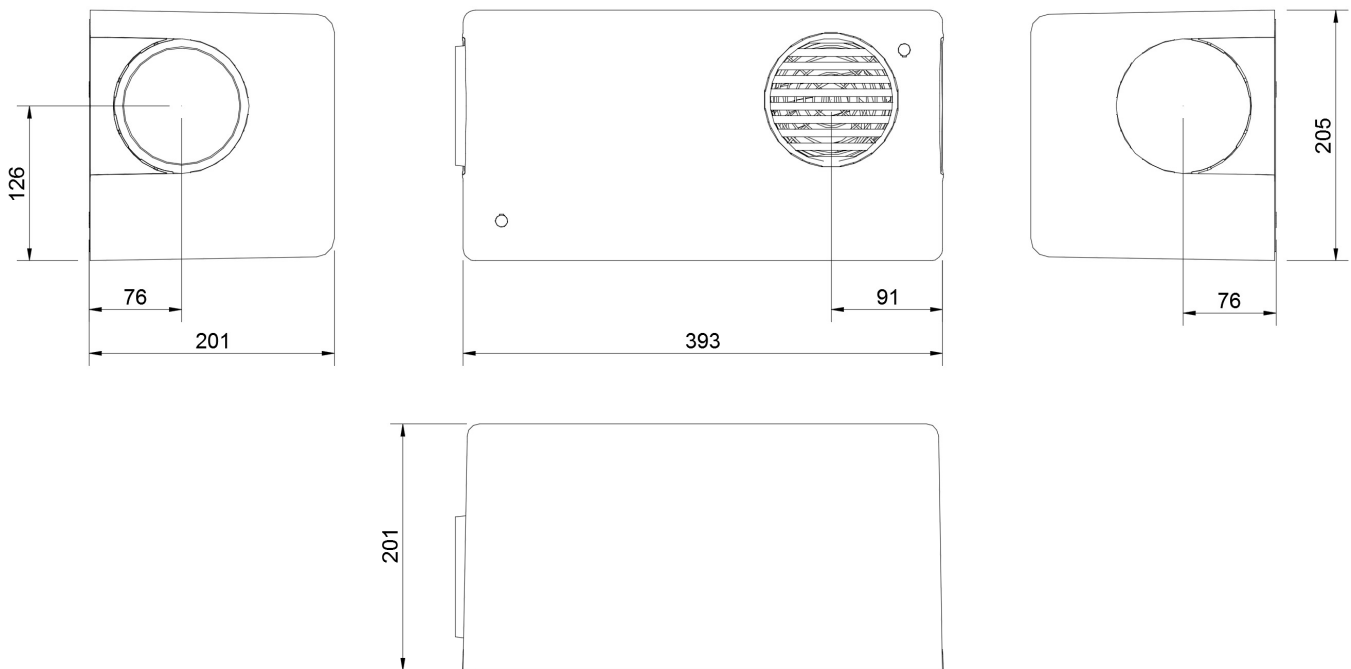

### **UNIT MOUNTING**

Unit to be mounted horizontally

To achieve optimal airflow, the unit should be mounted 1.8m from floor level.

If this is not possible, installation lower than 1.8m is safe and acceptable.

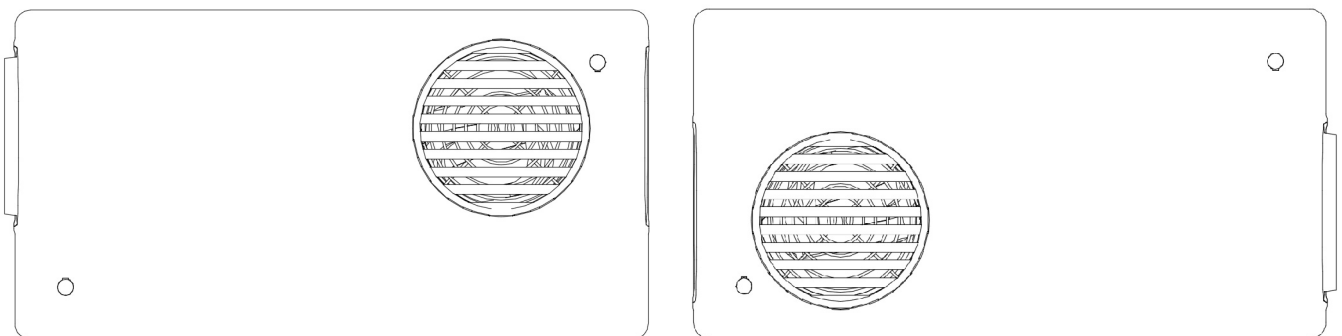

## TYPICAL INSTALLATIONS

### ABS COVER ONLY

See Inlet Options 1 or 2 for Install, page 8.

1. Insulate all ducting running from atmosphere and any ducting that passes through an unheated space. Choose either a side or rear inlet position for the unit.

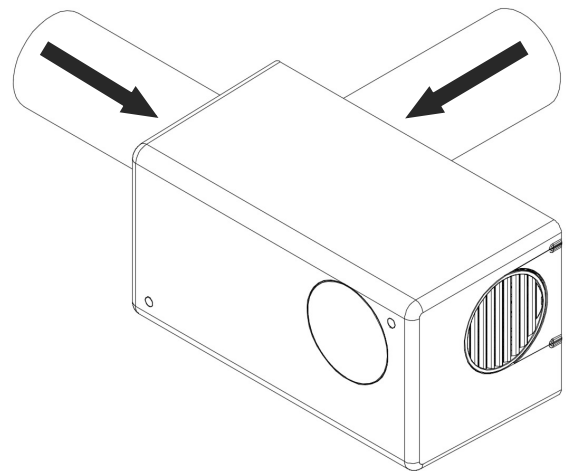
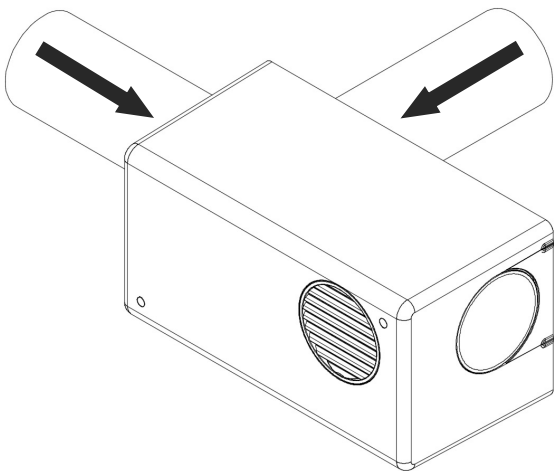

### FLEX DUCT INSTALL



1. Securely connect the flexible ducting to the unit's spigot, using worm-drive clip or cable ties. See page 12, Outlet Option 3 for Install details.
2. Extend the flexible ducting to its full length, to prevent moisture collection & avoids airflow issues.
3. Secure diffuser to flexible ducting, using worm-drive clip or cable ties. We recommend a maximum of 2m length of flexible duct (inlet and outlet) however, this could vary depending on the airflow requirements of the individual property. For the best performance and lowest noise, rigid ducting should be used where possible.

The diagram below is simplified, the inlet ducts, duct cover and clips are not shown, your installation may vary.

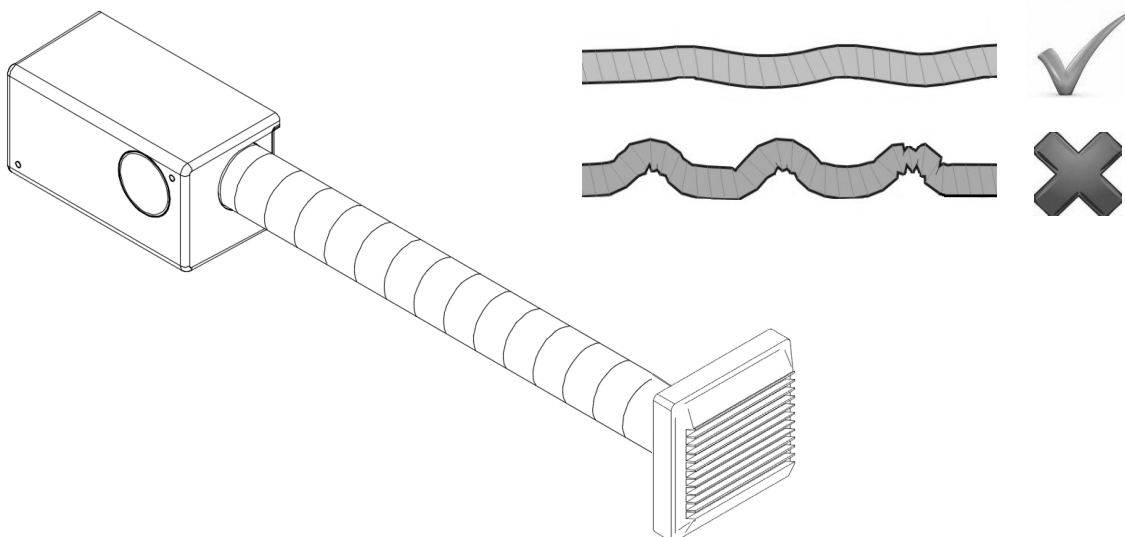

## **RIGID DUCT INSTALL**



1. Securely connect the rigid ducting to the unit's spigot, using a suitable adhesive. See Outlet Option 3 for Install, page 12.
2. Secure diffuser to the rigid ducting, using a suitable adhesive.
3. We recommend a maximum of 2.5m of rigid duct (Inlet and outlet) with a maximum of two 90° bends however, this could vary depending on the airflow requirements of the individual property.

The diagrams below are simplified, the inlet ducts, duct cover and clips are not shown, your installation may vary.

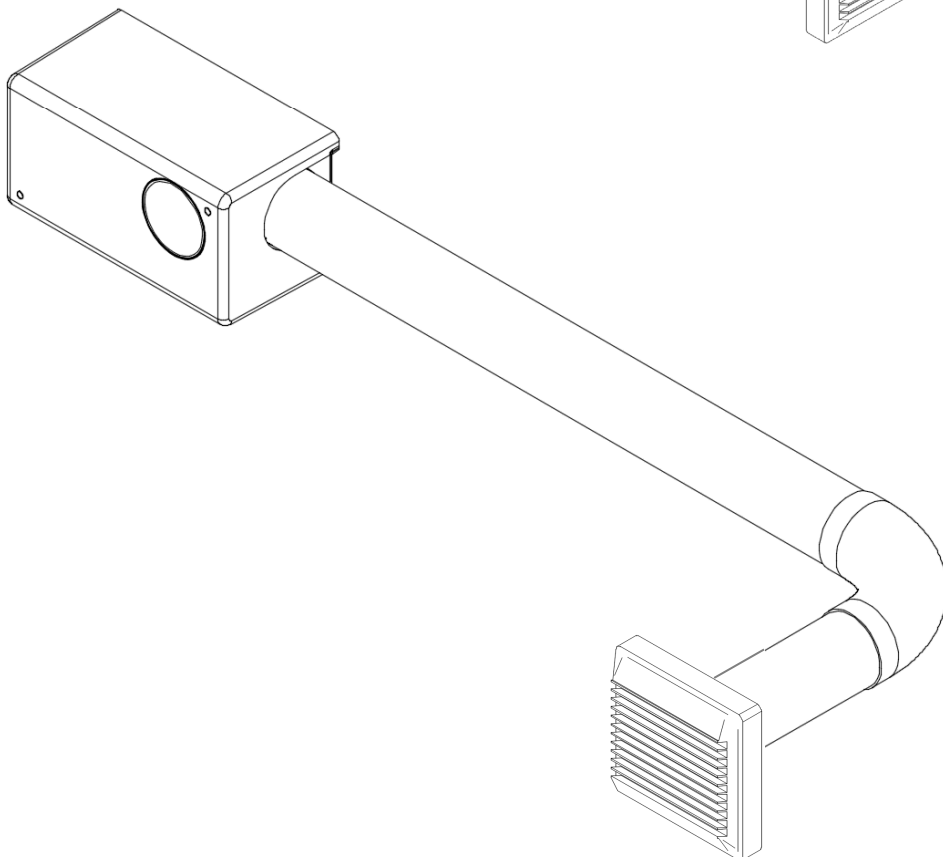
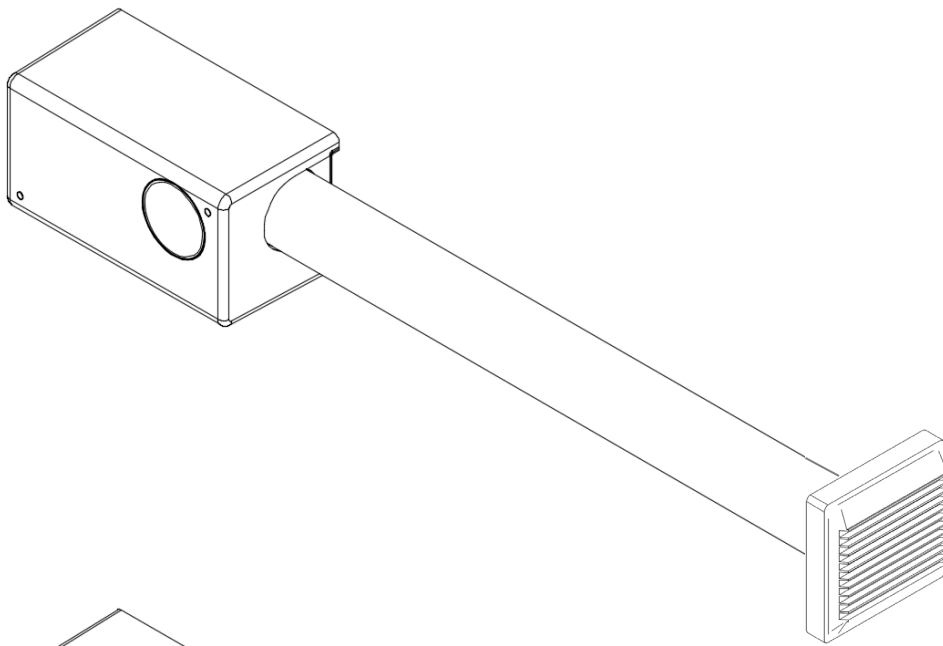

# **INSTALLATION**

The Unit is wall-mounted using the bracket and fixings supplied (or other suitable fasteners). Ensure there is sufficient space around the unit's base plate, when installing, to allow fitting & removal of the cover for servicing & maintenance. **(See image below)**.

The wall should have sufficient strength to support the unit.

Take into consideration the routing of the cable and the ducting that must be fitted to the inlet spigot.

The unit can be mounted vertically or horizontally on a vertical wall.



## **IMPORTANT**

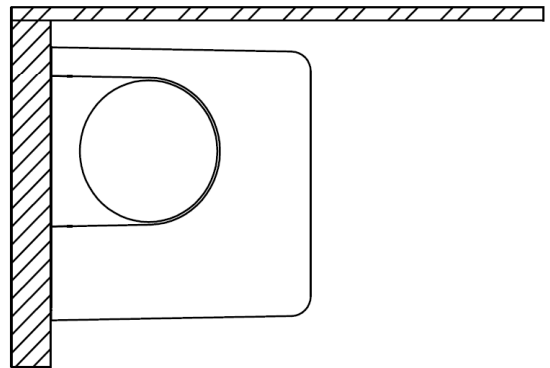
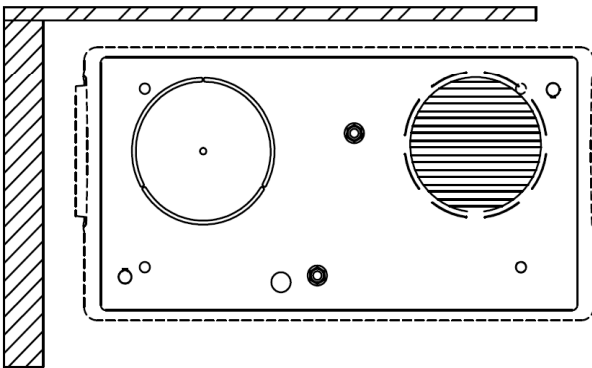
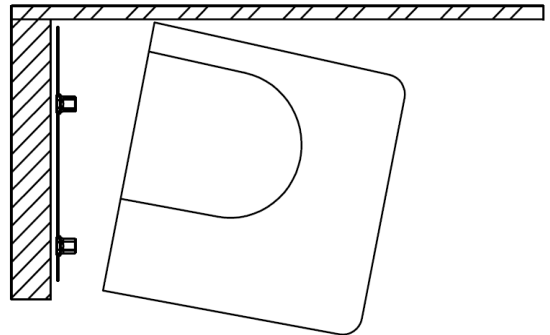
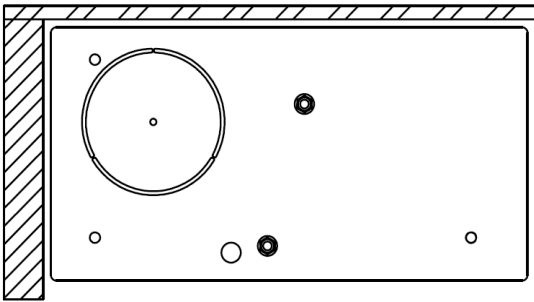

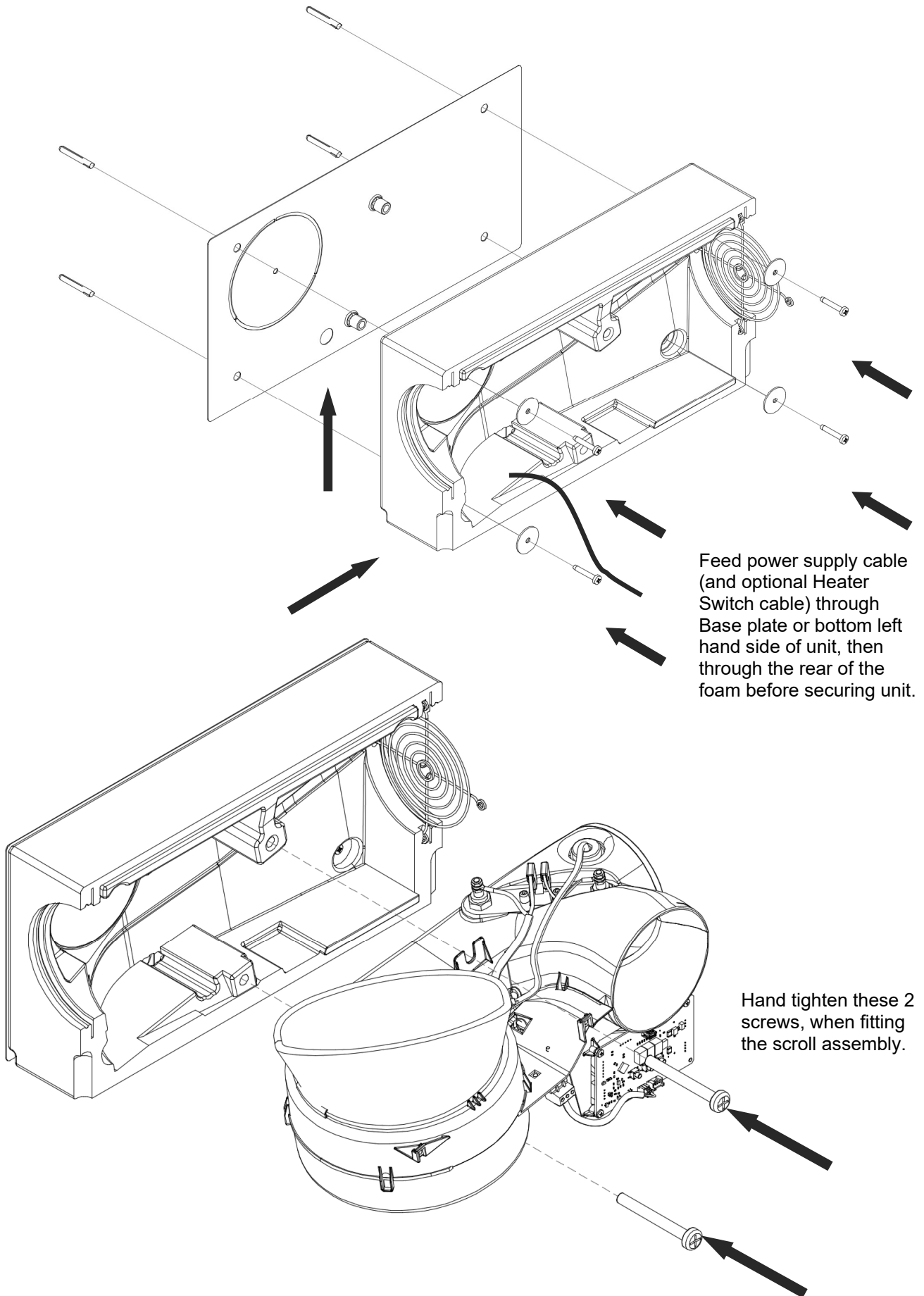

## INLET OPTIONS

### OPTION - 1

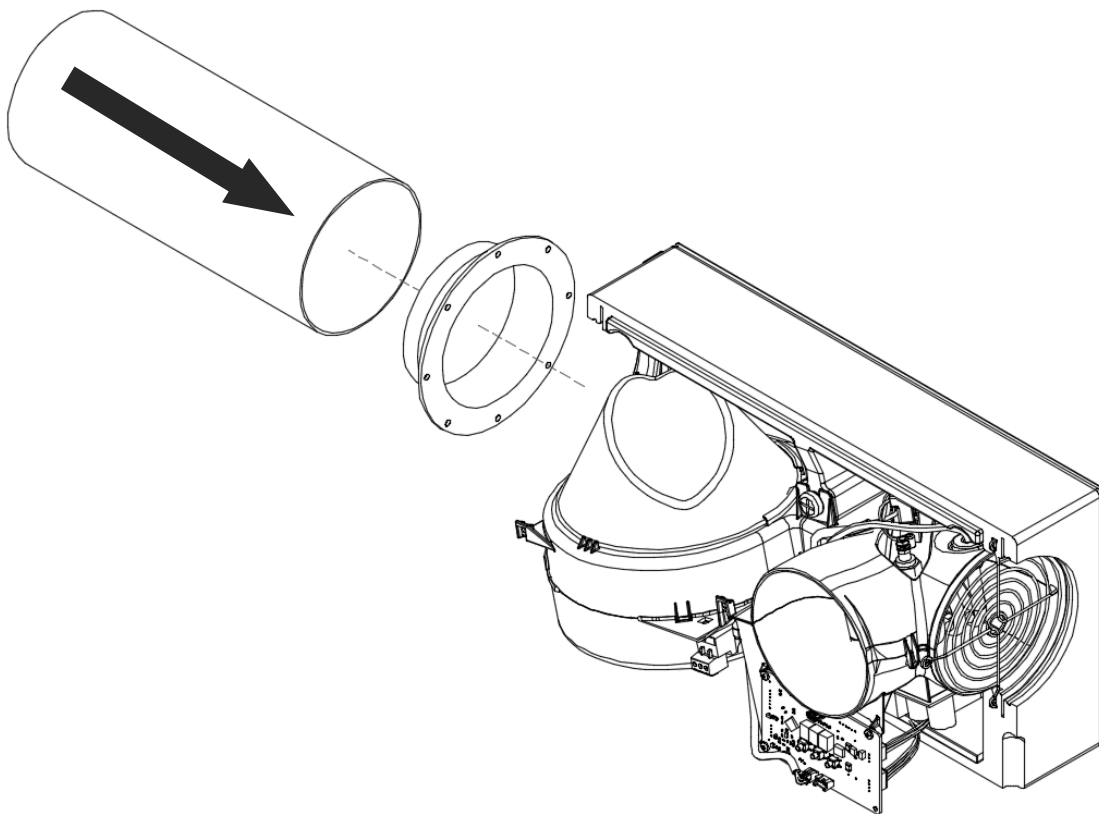

### OPTION - 2

If installing the unit with the air supply coming through the rear, the metal plate cut-out will need to be removed from base plate and the rear foam case will need to be cut-out before mounting. **See next page for details.**

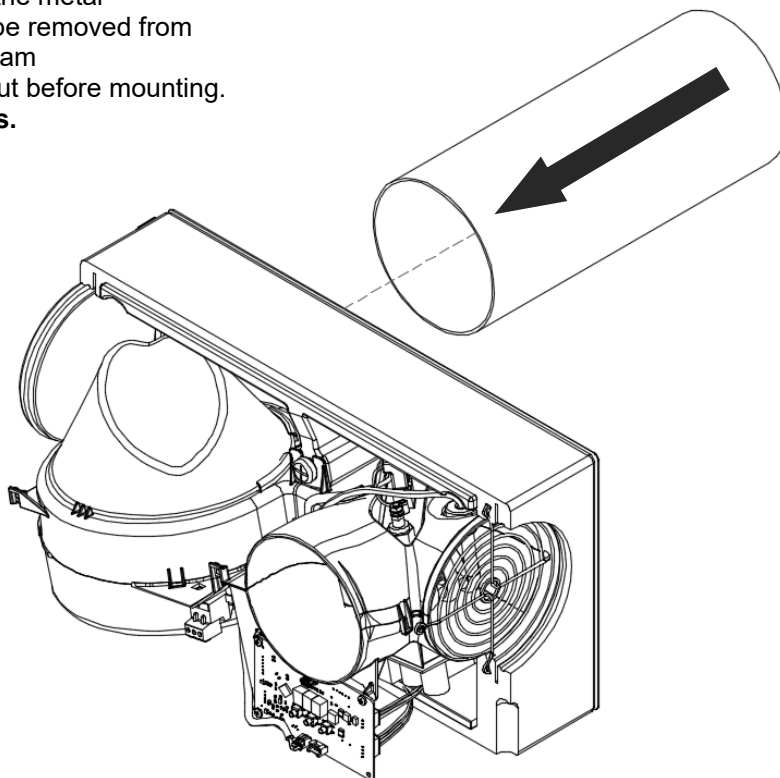

## Base Plate

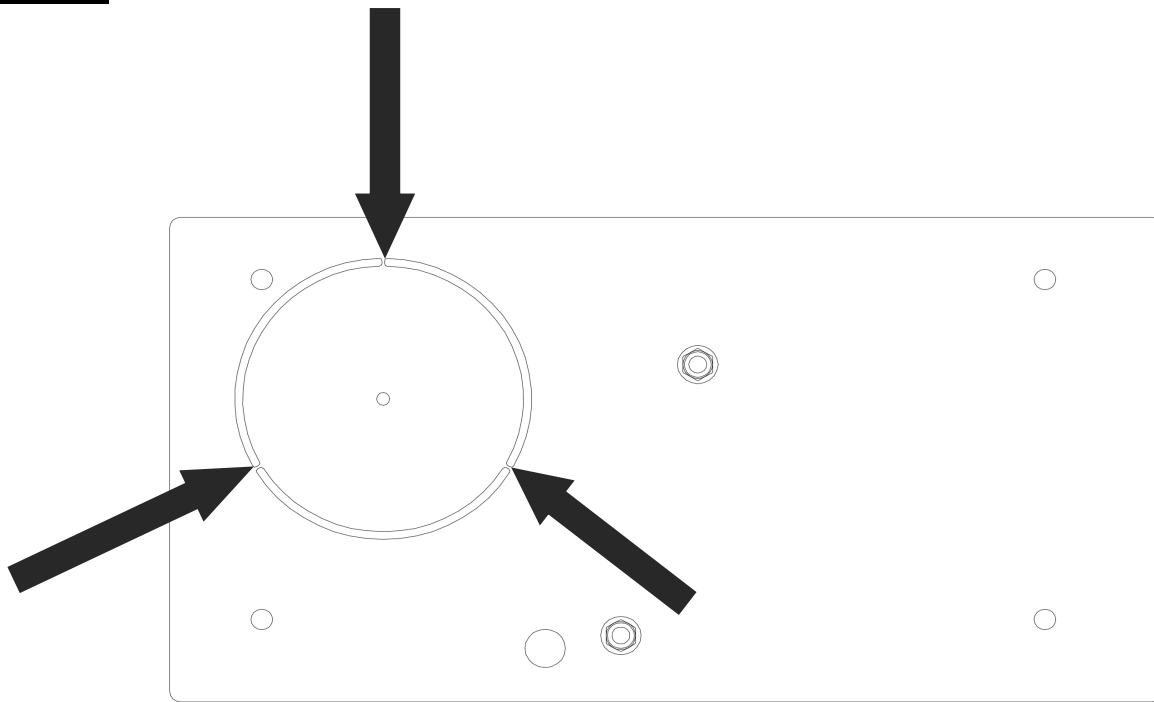

Snip the three tabs to remove the insert

## Rear Foam

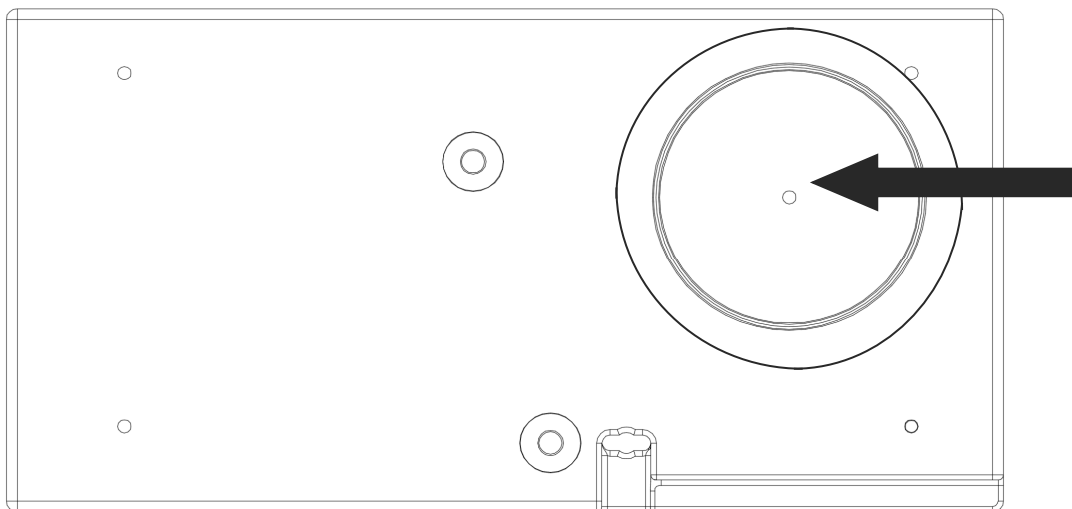

Using the centre mark, cut through the foam housing using a hole saw

## OUTLET OPTIONS

### OPTION - 1

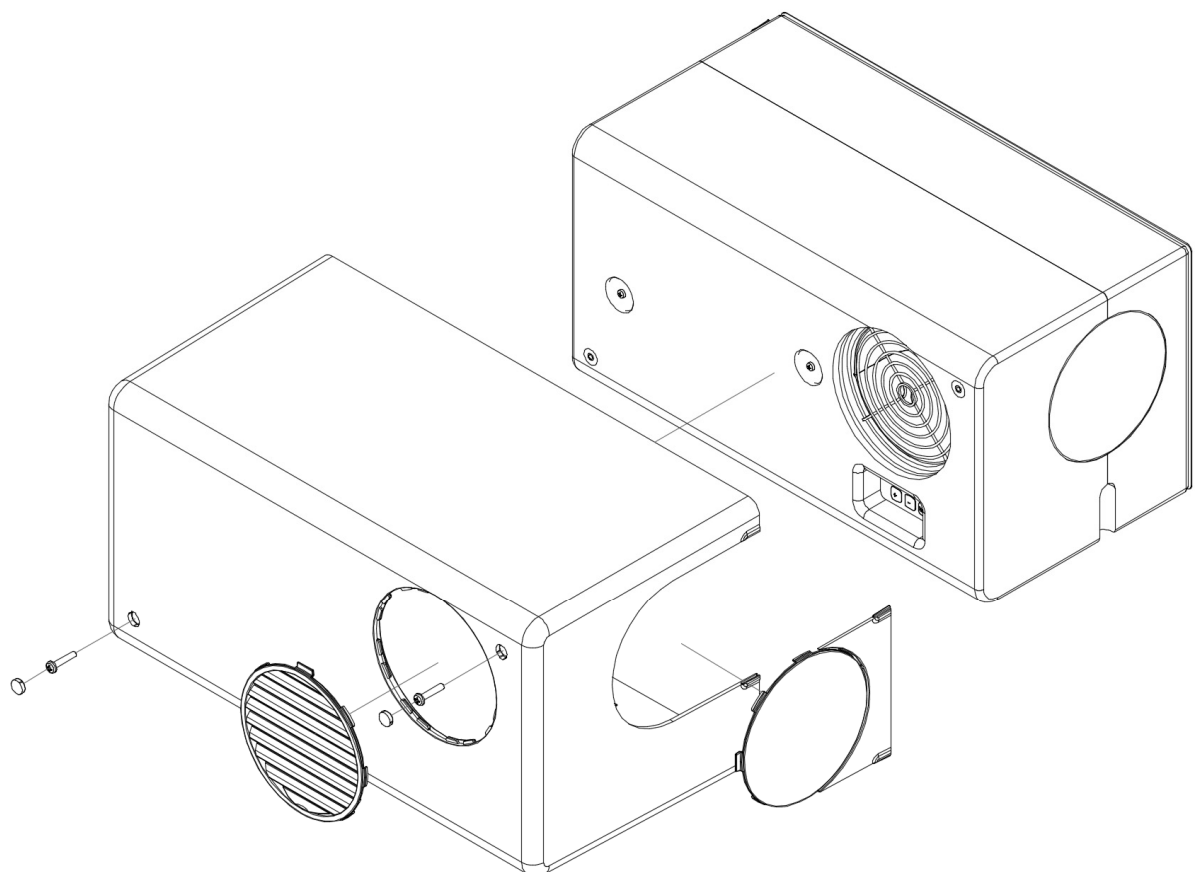
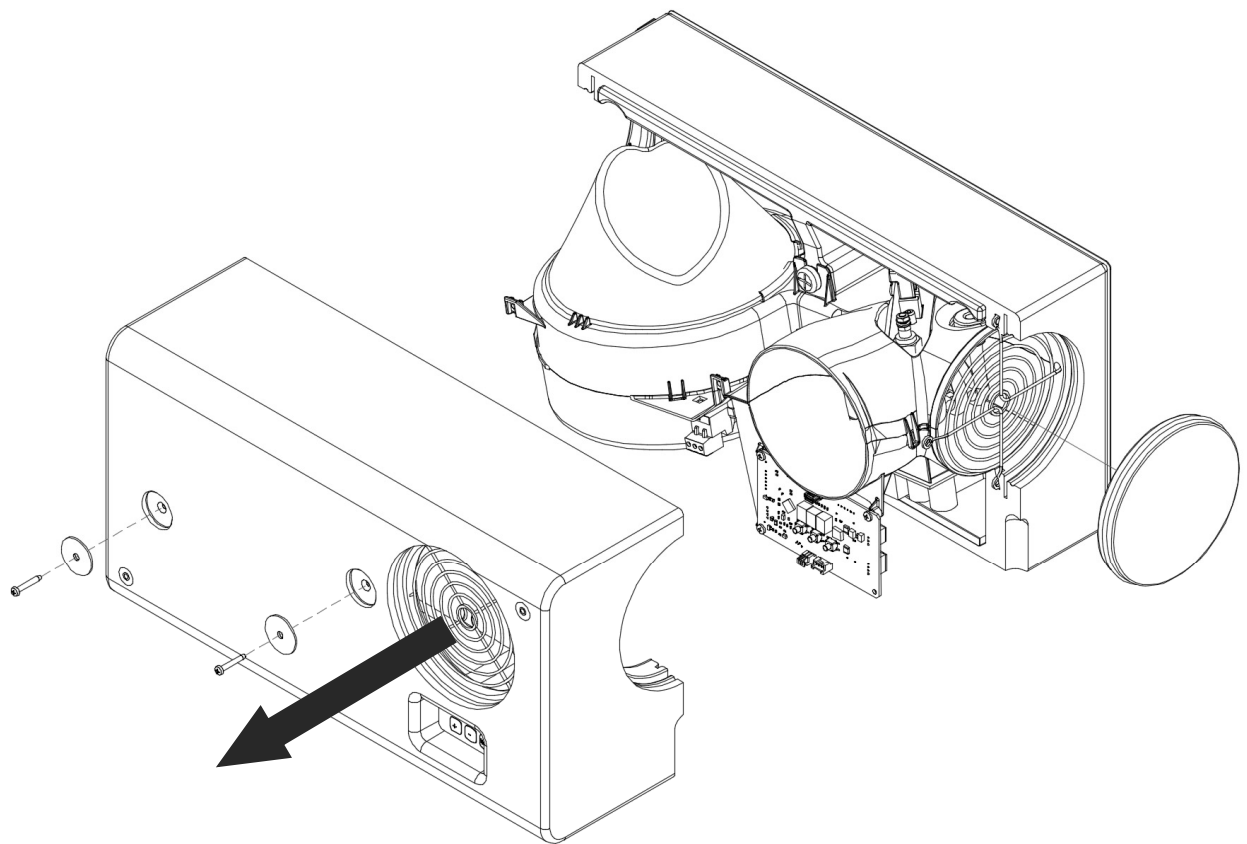

## OUTLET OPTIONS

### OPTION - 2

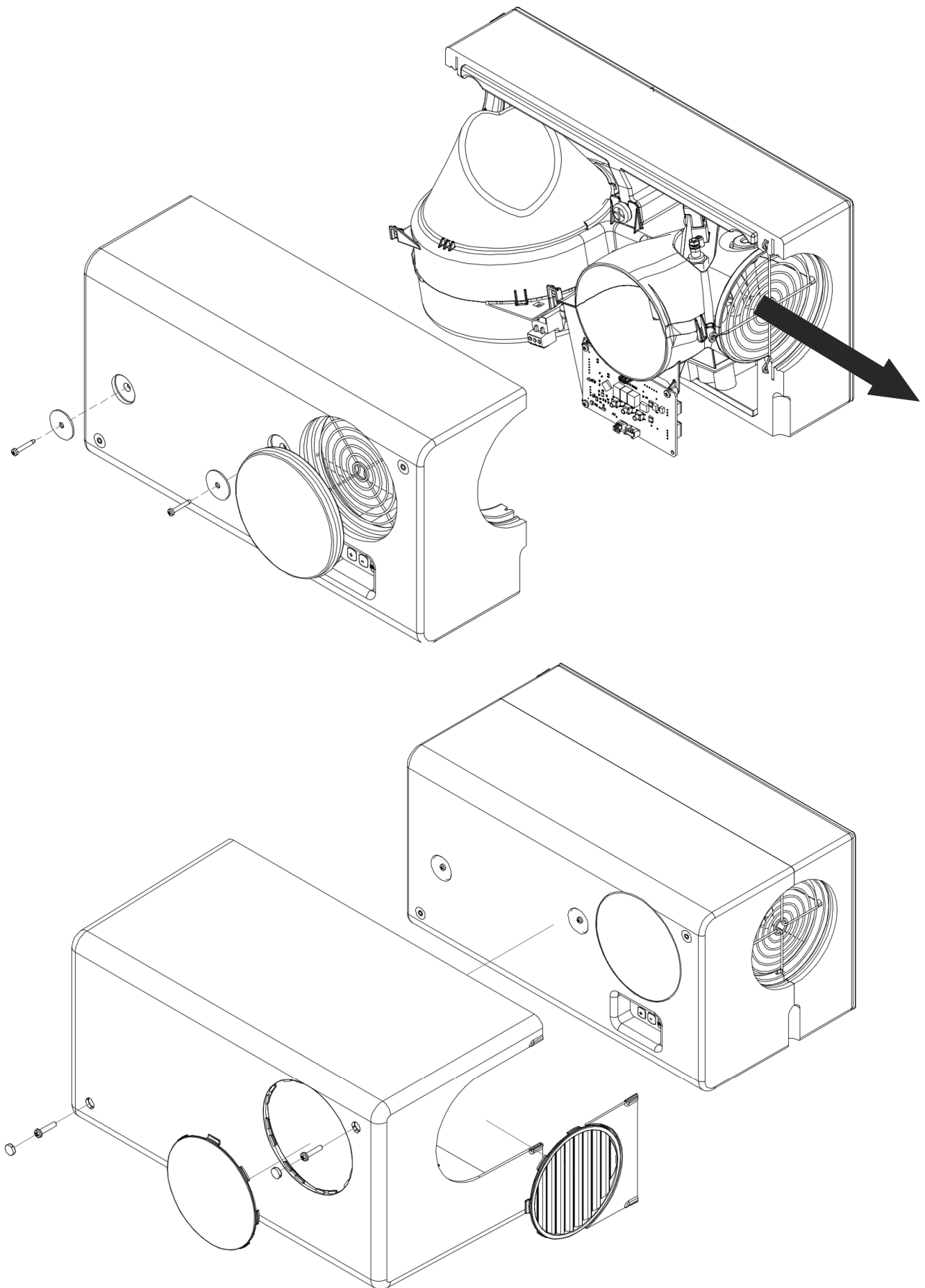

## OUTLET OPTIONS

### OPTION - 3

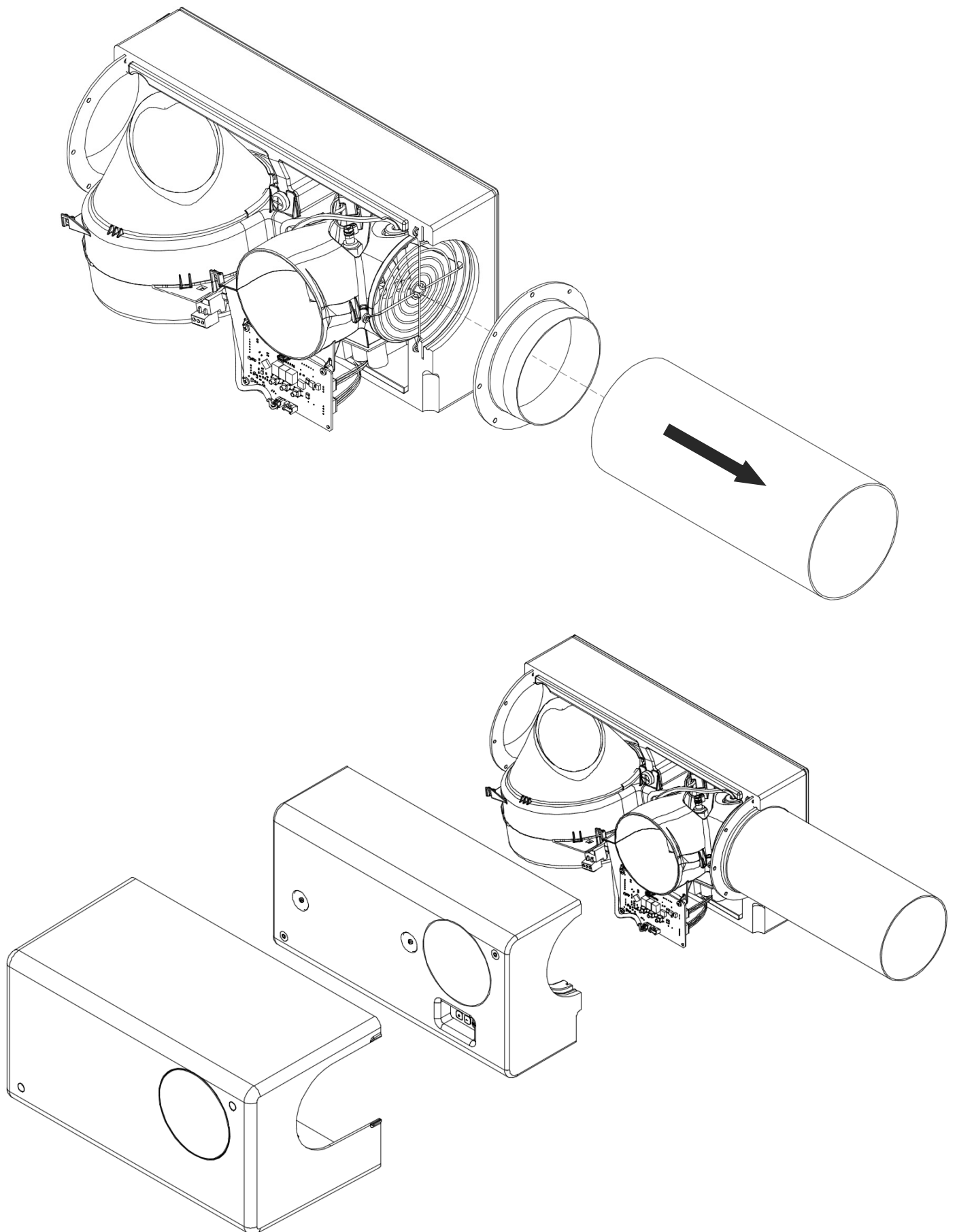

## **FILTER INSTALLATION**

Please make sure the filter is fitted correctly and retained on top of the scroll. This will ensure that all the fresh air entering the dwelling has passed through the filter first.

**Slide filter on top of scroll**

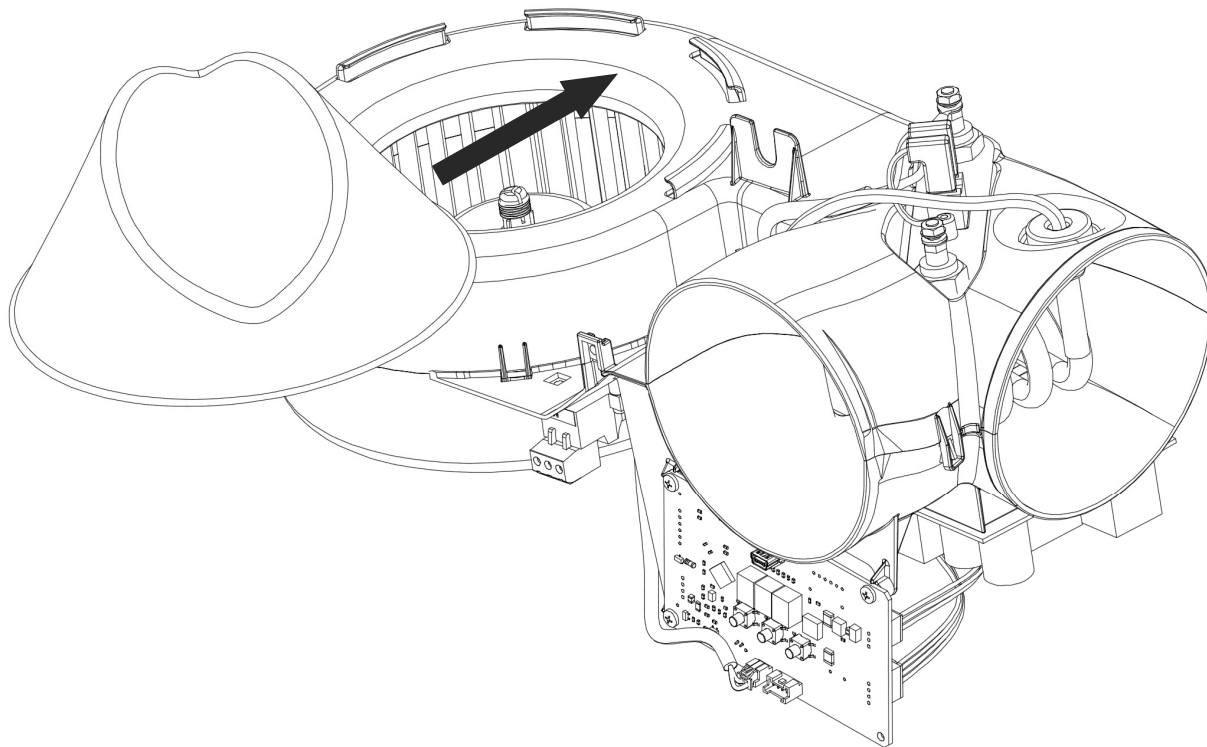

**Push filter over retaining clip to secure it in place.**

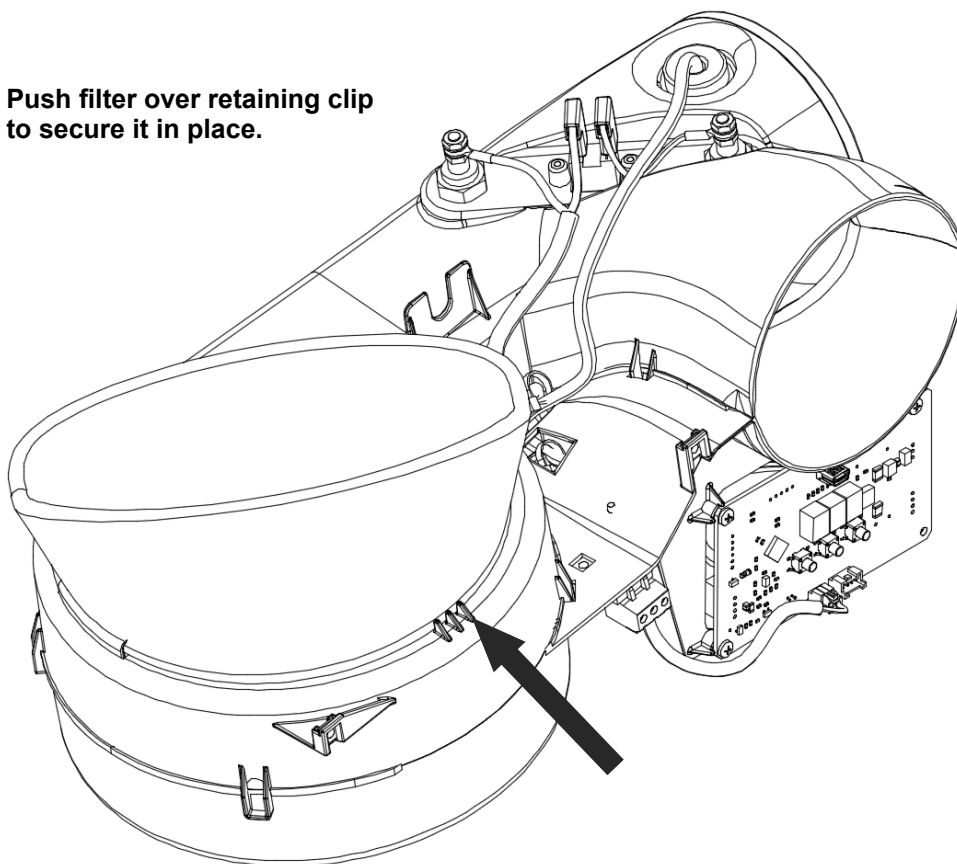

## **COVER PLATES – GRILLE & BLANKING**

When using the cover plates on the front of the unit, care must be taken when snapping them free.  
Only the cover plate that is being used in the front of the housing needs to be modified.  
It is recommended to install the grille facing towards the ceiling to minimise the effect of cold draughts

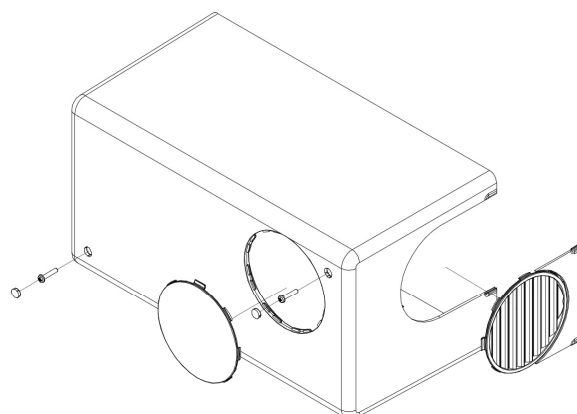
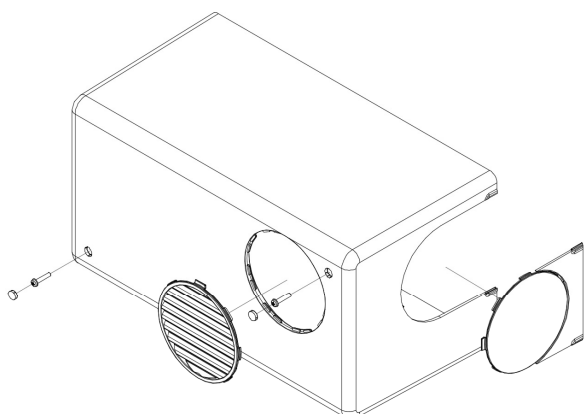
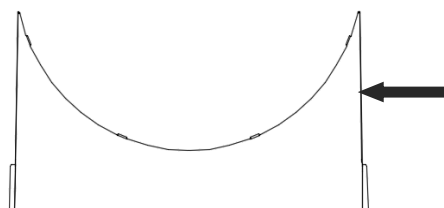
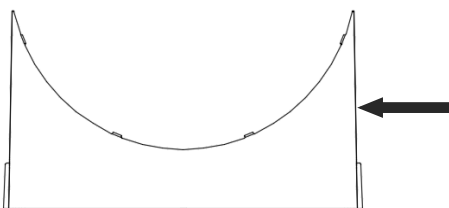
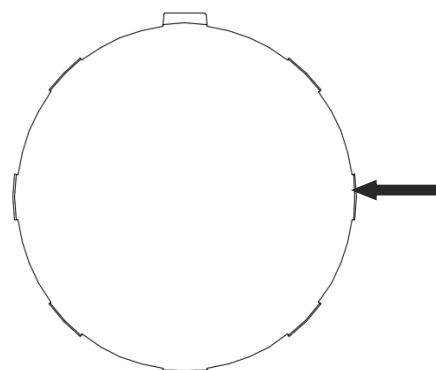
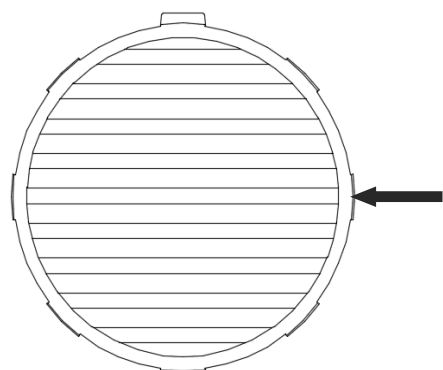
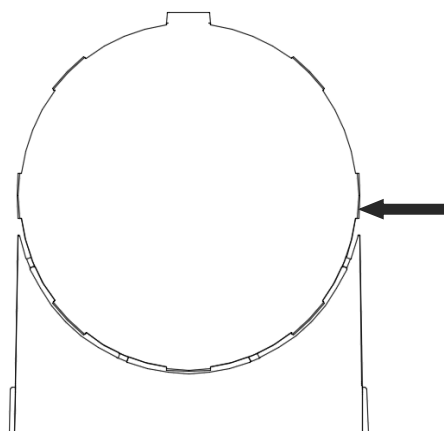
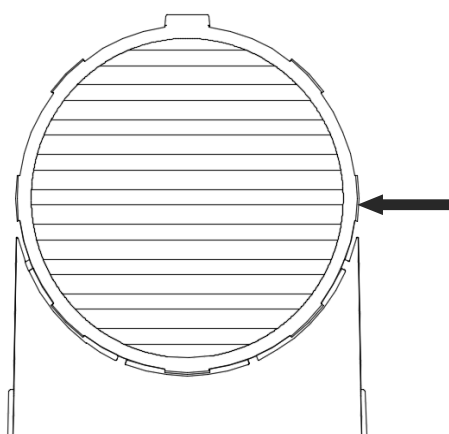

## WIRING

A means for disconnection must be incorporated, in the fixed wiring in accordance with the wiring regulations.



**WARNING: THE POSITIVE VENTILATION UNIT AND ANCILLARY CONTROL EQUIPMENT MUST BE ISOLATED FROM THE POWER SUPPLY DURING THE INSTALLATION / OR MAINTENANCE.**

Mains supply voltages (220-240V AC) are present in this equipment which may cause death or serious injury by electric shock. Only a qualified electrician or installer should connect the power supply to this unit. The Unit is designed for operation from a single-phase alternating current source (220-240V AC).

The unit must be connected with a suitable lead via a 3A switched fused spur. It should be capable of disconnecting all poles, having a contact separation of at least 3mm.

### OPTION – 1 (STANDARD WIRING)

**1 PHASE SUPPLY  
(220-204V ~ 50HZ)**

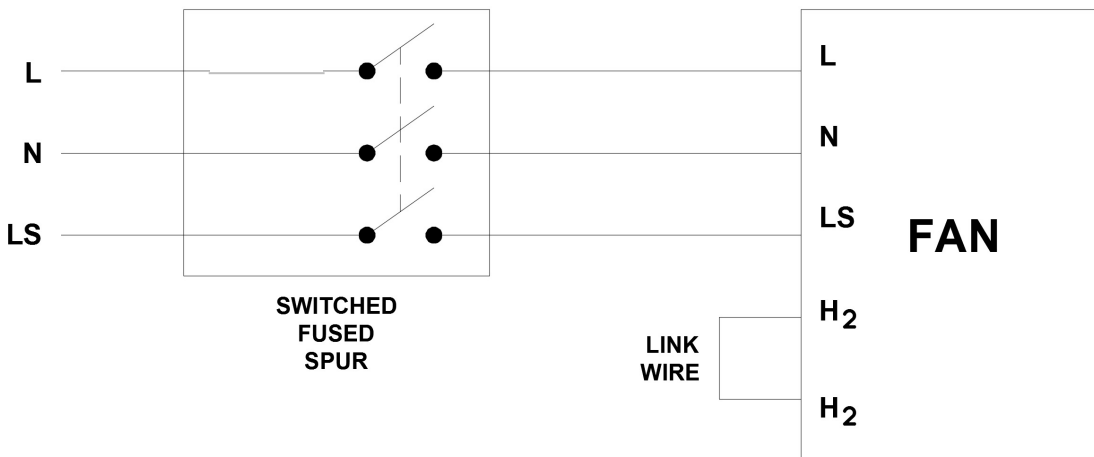

### OPTION – 2 (HEATER SWITCH WIRING) (Accessory - Pg.19)

**1 PHASE SUPPLY  
(220-204V ~ 50HZ)**

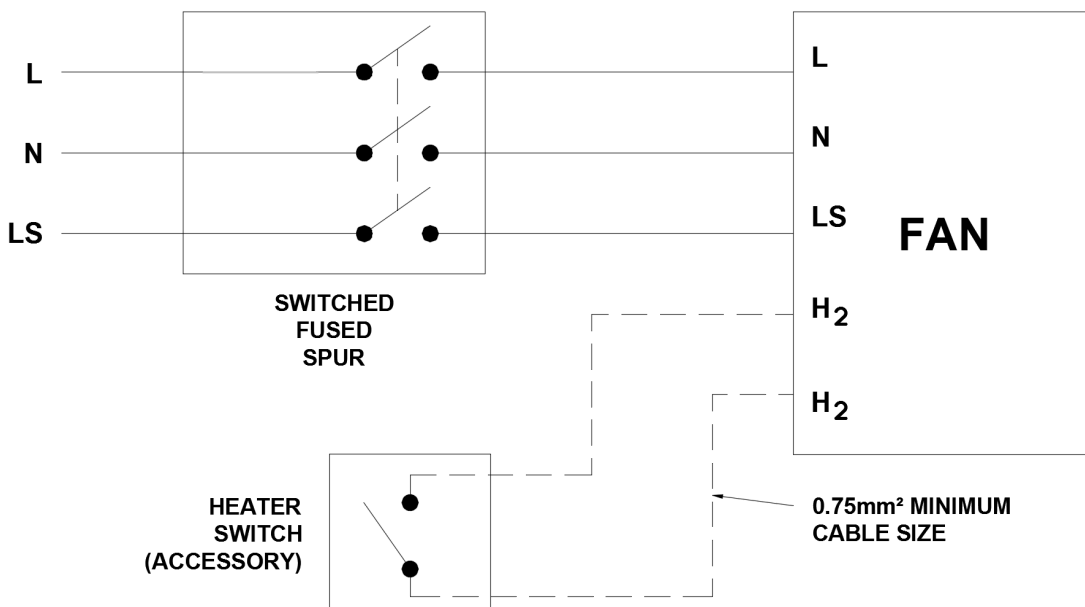

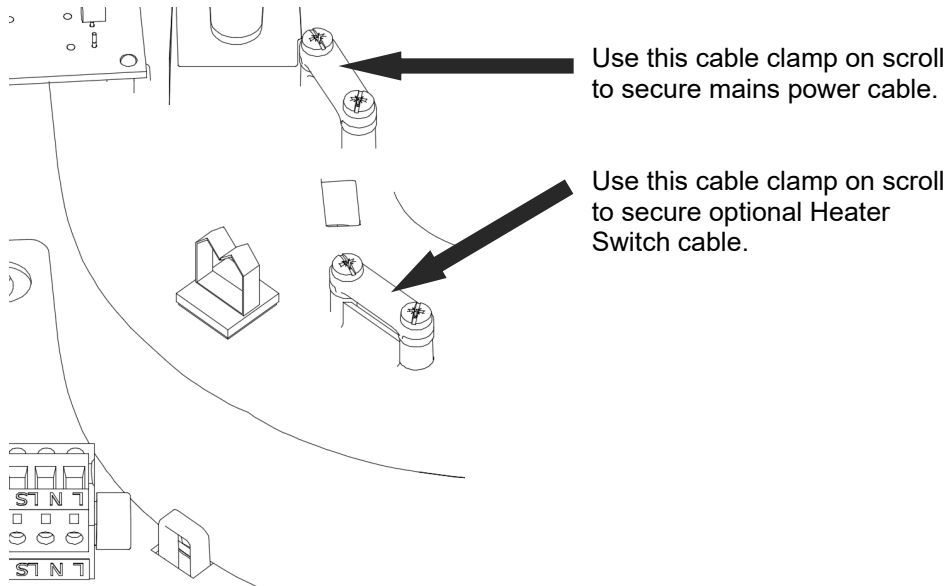

**SMOKE ALARM WIRING**  
**IMPORTANT:**

In order to have the product switch off in the event of a fire it must be wired using a smoke alarm with a relay system.

Use diagram as a reference and refer to the instructions provided by the manufacturer of the smoke alarm and relay in order to wire the unit correctly. Ensure the relay works correctly by testing the fire alarm; the unit should switch off when the alarm is sounding.

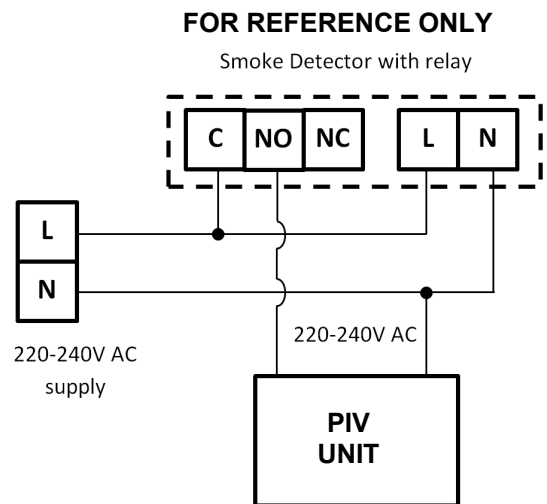

**START UP SEQUENCE**

When the unit is switched on it will first run through a period of system checks. During this time the display will show various system parameters before the fan motor starts. After 20 seconds the product will be ready for commissioning.

**COMMISSIONING**

**Accessing the Commissioning Menu**

If the fan is powered and the display is not lit, then press any button to access the menu. After 30 seconds without menu activity the display will switch off, any changes to the settings will then be applied.

There are three buttons on the front of the unit:

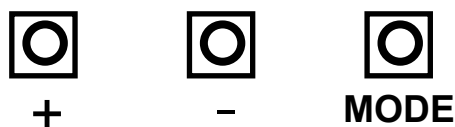

The + button is used to increase the value of a setting, the – button is used to reduce the value of a setting and the Mode button moves to the next menu item.

## **LOCK FEATURE**

The lock feature will prevent the unit from being adjusted after commissioning as a pass code is required to access the menu. This can be set in the menu to any 3 digit hexadecimal combination.

If the lock feature is enabled; when a button is pressed the display will show, – – –. At this point enter the three digit code by first pressing + or – until the first digit is correct then press MODE to move to the next digit. Repeat until the code is entered and press MODE to enter the commissioning menu. If the code is entered incorrectly, wait until the screen switches off then press any button to begin again.

## **AIR FILTER**

The Unit is provided with an ISO Coarse (G4) filters which are suitable for removing airborne contaminants such as pollen and dust.

Where improved filtration is required optional ISO ePM2.5 (F7) filters can be used. These filters are effective at removing finer particles such as particulate emissions from diesel engines. In urban areas close to main roads, ISO ePM2.5 (F7) filters are advisable in order to ensure the supply air is clear of these particles which are potentially harmful to health.

[www.vent-axia.com/filters](http://www.vent-axia.com/filters)

**Where ISO ePM2.5 (F7) filters are fitted, please ensure the flow rate of the fan is as expected. F7 filters cause extra system resistance so it may be necessary to increase the fan speed to compensate.**

## **COMMISSIONING MENU STRUCTURE**

Display text	Installation Option	Selections	
rot-rot	Display rotation*	rot-rot = Default	rot = Rotated 180°
d-n / d-y	Ducted Yes/No	d-n = Default	d-y = Yes
p-n / p-y	Preset Speed No/Yes	p-n = No	p-y = Yes
b01 - b02	Number of Bedrooms 1-2	b01/02 = Range	b01 = Default
t10 – t30	Flowrate 10-30 L/s	t10 – t30 L/s	
c05 – c20	Heater set point 5-20°C	c05-c20°C	c05 = Default
F.G4 – F.F7	Filter fitted G4/F7	G4 = Default	F7 = Optional
r-n / r-y	Radon mode No/Yes	r-n = Default	r-y = Yes
t26 – t35	Summertime cut-off 26-35°C	t26 – t35 = Range	t27 = Default
bst	Boost Overrun Time	0, 1, 2, 4, 8 hr	0 = Default
c-n / c-y	Comfort Mode Yes/No	c-n = No	c-y = Yes
unl / loc	Lock feature On/Off**	unl = unlocked	loc = Locked
cod	Lock code***	Set between 0 - F	

\* This setting rotates the display only; the buttons retain their original function. For example; the mode button is on the right when in normal rotation and on the left when the screen is rotated and looking at the fan so the display is correctly orientated.

\*\* Display: unl

Description: menu lock on or off. When locked a code is required to access the menu

Options: unl – unlocked Loc – Locked.

\*\*\* Display: cod

Description: Set the menu lock code. This is a 3 digit hexadecimal code, set between 0 - F.

Options: press up or down to start choosing the first digit then press mode to set and move to the next digit. Repeat to set the other two digits. Default override code is 999.

For most installs the standard features allow for ample adjustability, however in some install situations the advanced features will improve the unit's performance or acceptability.

**Radon mode** keeps the fan running even at high temperatures to prevent the build-up of dangerous radon gas in the property. If this is not required it is recommended not to use this setting.

## **SPEED SETTINGS**

The unit will run constantly at the set speed, with the following exceptions.

If the ambient inlet temperature exceeds the Summertime Cut-off temperature (27°C default), the Unit automatically switches to standby (no airflow). If Radon Mode is enabled, the Unit will continue to run beyond the normal threshold temperature, up to the maximum operating temperature of 40°C.

**Purge/Boost-Mode:** Boost-mode is initiated when an LS signal is detected. The fan speed will then be set to maximum until the LS signal is removed.

The speed settings on the Unit are fully adjustable between 10 L/s and 30 L/s via the manual speed setting option. Alternatively there are 2 Pre-set speeds, the speed settings relate to the number of bedrooms with, for example, setting b02 being for a two bedroom dwelling. For the approximate flow rates at each setting see table below. The Unit must be set to provide adequate ventilation according to Part F of the building regulations.

### **Ducted Mode – No** **When No Ducting is used**

Number of Bedrooms	L/s	Power (W)
b01	19	9W
b02	25	18W
LS/Boost	25	18W

### **Ducted Mode – Yes** **When Ducting is used**

Number of Bedrooms	L/s	Power (W)
b01	19	11W
b02	25	18W
LS/Boost	25	18W

**The table shows a set up representative of a good, low resistance install. When F7 filters and/or a long duct run are used it may be necessary to use the manual speed selection to meet the required flow rate.**

It is the responsibility of the installer to ensure that appropriate speeds are selected.

When ducted mode is enabled, the fan speed is increased to compensate for the additional restriction caused by the fitted ducting.

## **COMFORT MODE**

The comfort mode feature offsets/delays the boost when LS has been activated until after LS has been deactivated (up to a maximum of 20 minutes). Therefore reducing any nuisance noise until after the user has left the room.

When LS is deactivated, fan will run at boost mode for the length of time the LS was present (up to a maximum of 20 minutes) plus the set overrun time.

If the Boost Switch was activated for less than 3 minutes, no boost will occur to prevent nuisance activations.

If the Boost Switch is still connected after 20 minutes, the fan will boost anyway. Once the Boost is disconnected, the fan will run for only 20 minutes plus the set overrun timeout.

**SERVICING AND MAINTENANCE.**



**WARNING: THE POSITIVE VENTILATION UNIT AND ANCILLARY CONTROL EQUIPMENT MUST BE ISOLATED FROM THE POWER SUPPLY DURING THE INSTALLATION / OR MAINTENANCE.**

The fan motor uses sealed ball bearings, and does not require further lubrication. Apart from filter change the Unit contains no user serviceable parts.

Under normal conditions; i.e. away from main roads and industrial areas it is recommended that the filter is checked annually and cleaned or replaced as necessary. Otherwise change as required.

The filter may be gently cleaned with a vacuum cleaner or washed in a soapy water solution and allowed to air dry before re-fitting. Do not dry the filter in a tumble dryer.

**When re-fitting make sure that the filter is fitted correctly. This will ensure that all the fresh air entering the dwelling has passed through the filter first.**

**ACCESSING DATA LOGGER MENU**

To access the menu for data that the unit stores press and hold the mode button for 5 seconds. The menu structure is shown below, press mode to move to the next item:

Display text	Description
tot run 00y 00d	Total run time in years and days
Fan EnErgy 00(Wh)	Energy used in last 24 hours displayed in Wh
Heat EnErgy 00(kWh)	Energy used in last 24 hours displayed in kWh
tot EnErgy 00.0	Total Energy used displayed in kWh
FiltEr – 100	Percentage duration left on filter life

**Data Examples**

← **Text scrolling from right to left**

In this example the display is showing a total run time of 1 year and 237 days.

tot run 01y 237d

← **Text scrolling from right to left**

In this example the display is showing 34Wh of energy consumption in the previous 24h.

24h EnErgy 034

To exit the menu press **MODE** for 5 seconds or wait for the screen to switch off.

**Spares and accessories available for the Pozidry Compact Pro:**

Spares and Accessories	Part Number
ABS COVER	479843
SILENCER KIT	479857
ACOUSTIC FLEXI DUCT	443273
ROUND TO RECTANGLE ADAPTOR - ø105mm to 55x110mm	400740
REPLACEMENT 3 BUTTON SCROLL ASSY	479859
FILTER ISO Coarse (G4) (White)	479860
FILTER ISO ePM2.5 (F7) (Green)	479861
WALL FITTING KIT	254102
HEATER SWITCH	479982



### Disposal

This product should not be disposed of with household waste. Please recycle where facilities exist. Check with your local authority for recycling advice.

## Vent-Axia<sup>®</sup>

### Guarantee

Applicable only to products installed and used in the United Kingdom. For details of guarantee outside the United Kingdom contact your local supplier.

Vent-Axia guarantees this product for 7 years from date of purchase against faulty material or workmanship. In the event of any part being found to be defective, the product will be repaired, or at the Company's option replaced, without charge, provided that the product:-

- Has been installed and used in accordance with the instructions given with each unit.
- Has not been connected to an unsuitable electricity supply. (The correct electricity supply voltage is shown on the product rating label attached to the unit).
- Has not been subjected to misuse, neglect or damage.
- Has not been modified or repaired by any person not authorised by the company.

#### IF CLAIMING UNDER TERMS OF GUARANTEE

Please return the complete product, carriage paid to your original supplier or nearest Vent-Axia Centre, by post or personal visit. Please ensure that it is adequately packed and accompanied by a letter clearly marked "Guarantee Claim" stating the nature of the fault and providing evidence of date and source of purchase.

The guarantee is offered to you as an extra benefit, and does not affect your legal rights

# Vent-Axia<sup>®</sup>

Head Office: Fleming Way, Crawley, West Sussex, RH10 9YX.

EU Authorised Representative: Vent-Axia Sigarenmaker 5 - 5521DJ Eersel Nederland [authorisedrep@vent-axia.nl](mailto:authorisedrep@vent-axia.nl)

**UK NATIONAL CALL CENTRE, Newton Road, Crawley, West Sussex, RH10 9JA**

SALES ENQUIRIES: Tel: 0344 8560590 Fax: 01293 565169

TECHNICAL SUPPORT: Tel: 0344 8560594 Fax: 01293 532814

For details of the warranty and returns procedure please refer to [www.vent-axia.com](http://www.vent-axia.com) or write to Vent-Axia Fleming Way, Crawley, RH10 9YX